

SILENT Series

INSTALL SILENCE, INSTALL QUALITY OF LIFE



The Quietest Extractors in the World in their Category



Lp
26,5
dB

AXIAL FLOW FANS

SILENT Series



SILENT-100



SILENT-200



SILENT-300

SILENT

Axial flow fans



SILENT-100 DESIGN

NEW



Axial flow fans for wall or ceiling installation, designed to solve ventilation problems in small rooms and bathrooms. The motors from the SILENT range are mounted on silent-elastic-blocks which absorb the vibrations. In this way not only is the noise from the extractor significantly reduced but so too is the noise from the surface which supports it. Additionally, the motors from the SILENT range are equipped with ball bearings which guarantee long life working (more than 30.000 working hours) at any shaft positions. The SILENT range consists of three different models: SILENT-100, SILENT-200 and SILENT-300, available with different integrated control options to accommodate all application requirements.

Installation examples

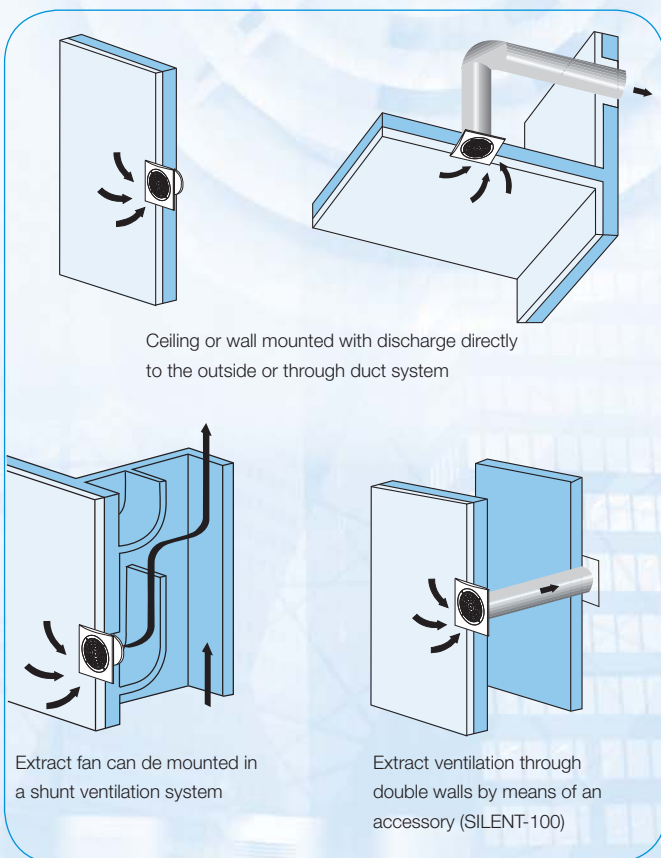

- C** All models are fitted with back draft shutter.
- Z** All models includes ball bearings greased for life (up to 30.000 hours).
- R** Model fitted with an adjustable period Run-On-Timer keeping the fan in operation for the pre set period of time after the fan has been switched off.
- H** Model with an adjustable humidistat.
- D** Model provided with a passive infra-red detector operating up to 4 m from the fan.



BATHROOM EXTRACT FANS

SILENT-100 Series

SILENT

Axial flow fans



Range of axial extractors with airflow rates of approx. 100 m³/h, for connection to 100 mm diameter circular ducting.

Motor mounted on silent-elastic-blocks which absorb the vibrations and allow offering very low noise level. All the fans are manufactured from injection moulded plastic, fitted with automatic shutter and single phase 230V-50Hz, class B low consumption motor equipped with overload thermal protection. All the fans are class II insulation, **IP45** rated and suitable to operate with air temperature up to 40°C.

Lp
26,5
dB

Low noise!

IP45

Water protected!

consumption
8W!

Energy efficient!

SILVER versions

The SILENT-100 CZ and CRZ can be supplied with an aesthetical silver front grille.

Back draft shutter



To prevent air entry and limit heat leakage when the extractor is not operating. It opens due to the pressure of the air

Silent-blocks



Motor mounted on "Silent-elastic-block" to prevent vibration and noise transmission

Quiet operation

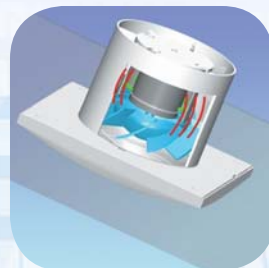

SILENT-100

In usual extract fans the vibrations are transmitted to the surrounding areas while in SILENT extractor fans the vibrations are absorbed by the Silent Blocks



Usual extractor

Models features

	CZ	CRZ	CRIZ	CHZ	CHZ VISUAL	CDZ	CZ (12V)	CZ SILVER	CRZ SILVER	CHZ SILVER	CZ(12V) SILVER
Pilot light	•	•	•	•	•	•	•			•	•
Backdraft shutter	•	•	•	•	•	•	•	•	•	•	•
Adjustable Run-On-Timer (1-30min)		•		•	•	•	*		•	•	*
Automatic timer			•								
Adjustable humidistat				•	•					•	
Detector movement						•				•	
Ball bearings	•	•	•	•	•	•	•	•	•	•	•
Silver colour								•	•	•	•

* Using CT-12/14R transformer

Technical characteristics

Model	Speed (r.p.m.)	Abs. power at free discharge (W)	Voltage (V) 50 Hz	Sound pressure level* (dB(A))	Airflow at free discharge (m ³ /h)	Insulation/ IP	Weight (kg)
SILENT-100	2400	8	230	26,5	95	II / IP45	0,57
SILENT-100 12V	2320	13	12	26,5	95	⊕ / IP57	0,57

* Sound pressure level measured at 3 m at free air conditions.

Dimensions (mm)

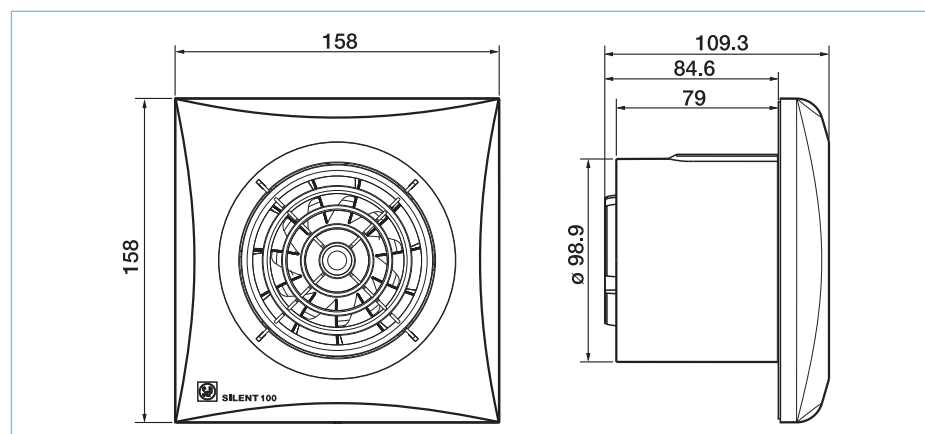

Performance curves

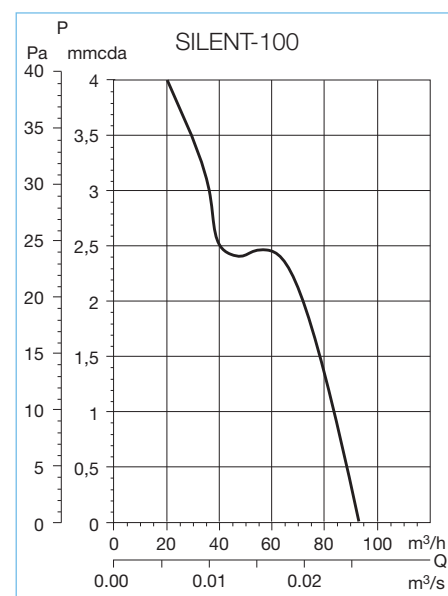

Accessories



GSA-100
Flexible aluminium ducting



GRA-70
Aluminium exterior grille



CX-80/125
Worm drive ducting clip



PER-100W
Back draft shutter



WALL KIT
Fixed shutter and telescopic duct (200 to 420 m)



WINDOW KIT

SILENT-100 models with special functions

SILENT

Axial flow fans



SILENT-100 CZ 12V

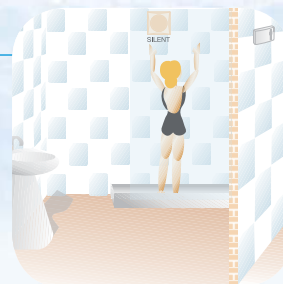

Model SELV (Safety Extra Low Voltage). Specially designed to operate within the shower or bath volume with total safety. They are rated 12V, Class III and IP57.



SILENT-100 12V must be wired to a safety isolating **transformer CT-12/14** which must be located out of the reach of the water spray or person using a bath or shower. The transformer is IP21, class II insulation and protected by fuse. Also available, **Transformer CT12/14 R**, supplied with adjustable run-on-timer between 1 to 30 minutes.

KIT SILENT-100 CZ 12V + CT

Kit integrated by an extractor SILENT-100 CZ 12V and a safety isolating transformer CT-12/14.



SILENT-100 CDZ

Model provided with a PIR (passive infra-red) detector. The unit starts automatically when a movement is detected within a maximum distance of 4 meters from the fan. They are also fitted with an adjustable "run on" timer, from 1 to 30 minutes, to allow the fan continues operating after the initiation of the movement detection.



SILENT-100 CHZ VISUAL

Models provided with an electronic humidistat which can be adjusted to 60, 70, 80 or 90% HR using a key situated on the front grille. Four luminous indicators show the desired level of humidity. The extractor operates automatically when the humidity level in the room is higher than the set level. The extractor will stop automatically when the humidity drops below the selected level and after the selected period set on the adjustable timer (1 and 30 minutes).





BATHROOM EXTRACT FANS

SILENT-100 DESIGN Series

NEW



Range of axial extractors with airflow rates of approx. 80 m³/h, for connection to 100 mm diameter circular ducting.

Motor mounted on silent-elastic-blocks which absorb the vibrations and allow offering very low noise level. All the fans are manufactured from injection moulded plastic, fitted with

automatic shutter and single phase 230V-50Hz, class B low consumption motor equipped with overload thermal protection. All the fans are class II insulation, **IP45** rated and suitable to operate with air temperature up to 40°C.



Lp
26,5 dB

Low noise!

IP45

Water protected!

consumption
8W!

Energy efficient!

SILVER versions can be supplied with an aesthetical silver front grille.

SILENT

Axial flow fans

Back draft shutter



To prevent air entry and limit heat leakage when the extractor is not operating. It opens due to the pressure of the air

Silent-blocks



Motor mounted on "Silent-elastic-block" to prevent vibration and noise transmission

Quiet operation

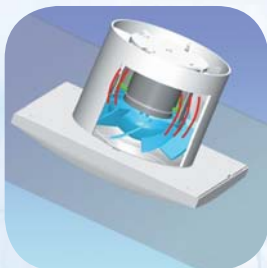

SILENT-100

In usual extract fans the vibrations are transmitted to the surrounding areas while in SILENT extractor fans the vibrations are absorbed by the Silent Blocks

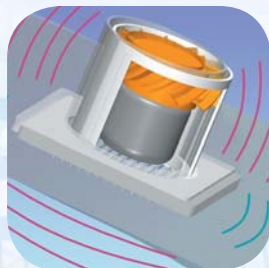

Usual extractor

Kit 3 front panel trims



Interchangeable front panel trims let the fan blend in with every setting: Transparent blue evokes the colour "of water". 3 other colours to match the decor of the room

Models features

	CZ DESIGN	CRZ DESIGN	CHZ DESIGN	CZ SILVER DESIGN	CRZ SILVER DESIGN	CHZ SILVER DESIGN	CZ DESIGN 3C	CRZ DESIGN 3C	CHZ DESIGN 3C	CZ SILVER DESIGN 3C	CRZ SILVER DESIGN 3C	CHZ SILVER DESIGN 3C
Pilot light	•	•	•	•	•	•	•	•	•	•	•	•
Backdraft shutter	•	•	•	•	•	•	•	•	•	•	•	•
Adjustable Run-On-Timer (1-30min)		•	•		•	•		•	•		•	•
Adjustable humidistat			•			•			•			•
Ball bearings	•	•	•	•	•	•	•	•	•	•	•	•
Silver colour				•	•	•				•	•	•
kit 3 front panel trims							•	•	•	•	•	•

Technical characteristics

Model	Abs. power at free discharge (W)	Voltage (V) 50 Hz	Sound pressure level* (dB(A))	Airflow at free discharge (m ³ /h)	Insulation/ IP	Weight (kg)
SILENT-100 DESIGN	8	230	26,5	80	II / IP45	0,65

* Sound pressure level measured at 3 m at free air conditions.

Dimensions (mm)

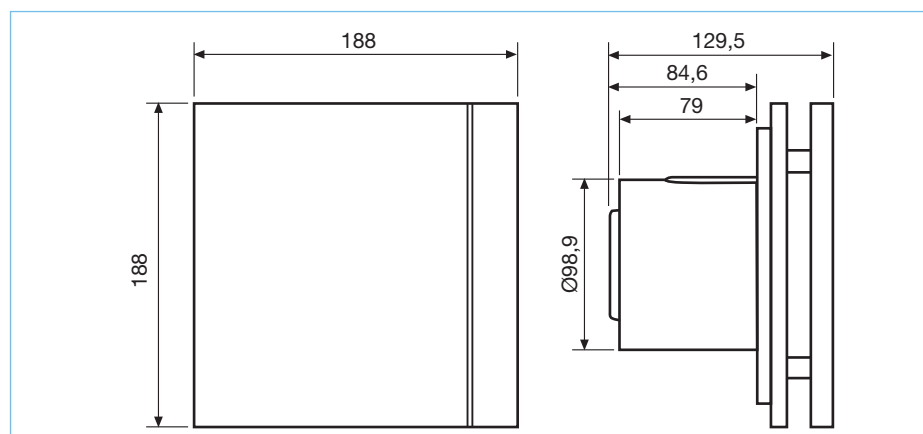

Performance curves

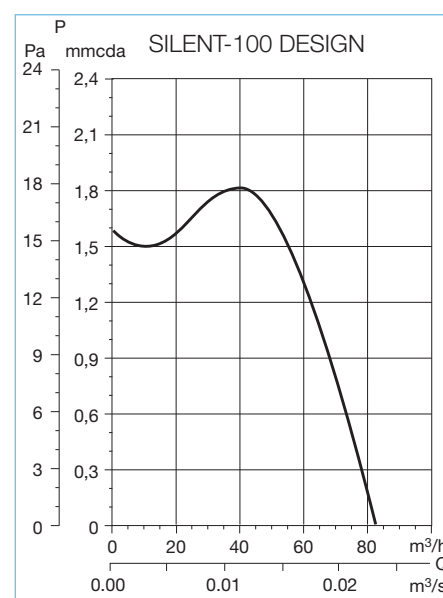

Accessories



GSA-100
Flexible aluminium ducting



GRA-70
Aluminium exterior grille



CX-80/125
Worm drive ducting clip



PER-100W
Back draft shutter



WALL KIT
Fixed shutter and telescopic duct (200 to 420 m)



WINDOW KIT

BATHROOM EXTRACT FANS

SILENT-200 Series



IP45



Range of axial extractors with airflow rates of approx. 180 m³/h, for connection to 120 mm diameter circular ducting.

Motor mounted on silent-elastic-blocks which absorb the vibrations and allow offering very low noise level. All the fans are manufactured from injection moulded plastic, fitted with automatic shutter and single phase 230V-50-Hz, class B low consumption motor equipped with overload thermal protection. All the fans are class II insulation, **IP45** rated and suitable to operate with air temperature up to 40°C. The SILENT-200 CZ and CRZ can be supplied with an aesthetical silver front grille.

SILENT

Axial flow fans

Back draft shutter



To prevent air entry and limit heat leakage when the extractor is not operating. It opens due to the pressure of the air

Silent-blocks



Motor mounted on "Silent-elastic-block" to prevent vibration and noise transmission

Quiet operation

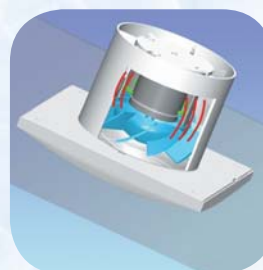

SILENT-200

In usual extract fans the vibrations are transmitted to the surrounding areas while in SILENT extractor fans the vibrations are absorbed by the Silent Blocks

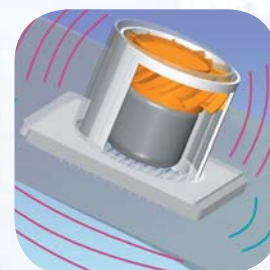

Usual extractor

Models features

	CZ	CRZ	CHZ	CZ SILVER	CRZ SILVER	CHZ SILVER
Pilot light	•	•	•	•	•	•
Backdraft shutter	•	•	•	•	•	•
Adjustable Run-On-Timer (1-30min)		•	•		•	•
Adjustable humidistat			•			•
Ball bearings	•	•	•	•	•	•
Silver colour				•	•	•

Technical characteristics

Model	Speed (r.p.m.)	Abs. power at free discharge (W)	Voltage (V) 50 Hz	Sound pressure level* (dB(A))	Airflow at free discharge (m ³ /h)	Insulation / IP	Weight (kg)
SILENT-200	2350	16	230	33	180	II / IP45	0,77

* Sound pressure level measured at 3 m at free air conditions.

■ **Dimensions (mm)**

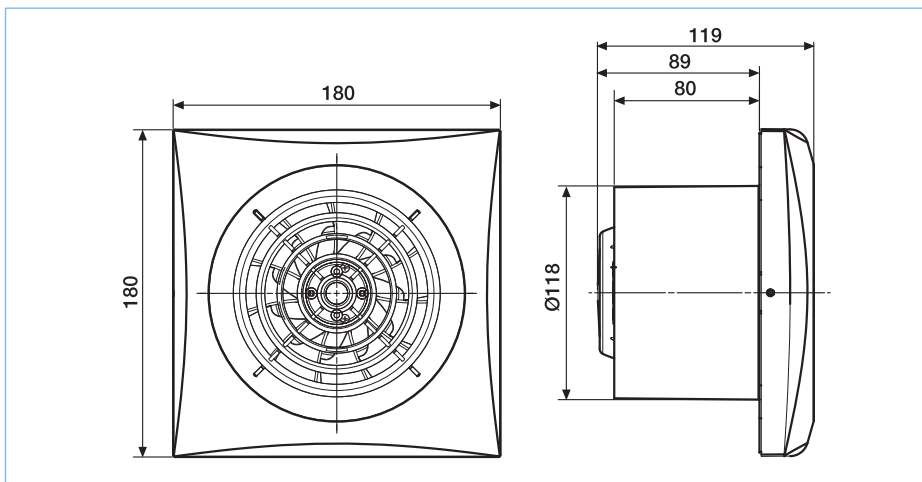

■ **Performance curves**

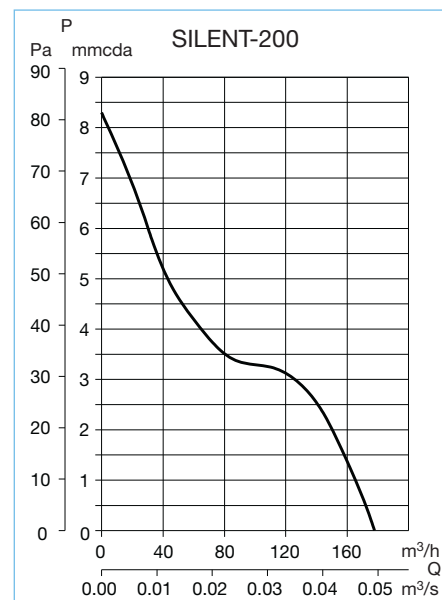

■ **Accessories**



GSA-125
Flexible aluminium ducting



GRA-150
Aluminium exterior grille



CX-125/215
Worm drive ducting clip



PER-125W
Back draft shutter



AXIAL EXTRACT FANS

SILENT-300 and SILENT-300 PLUS Series



Range of axial extractors with airflow rates of approx. 300 m³/h, for connection to 150-160 mm diameter circular ducting.

Motor mounted on silent-elastic-blocks (SILENT-300) which absorb the vibrations and allow offering very low noise level. All the fans are manufactured from injection moulded plastic, fitted with automatic shutter and single phase 230V-50Hz, class B low consumption motor equipped with overload thermal protection. All the fans are class II insulation, **IP45** rated and suitable to operate with air temperature up to 40°C.

The SILENT-300 CZ and CRZ can be supplied with an aesthetical silver front grille.

IP45

Back draft shutter



To prevent air entry and limit heat leakage when the extractor is not operating. It opens due to the pressure of the air

Silent-blocks



Motor mounted on "Silent-elastic-block" to prevent vibration and noise transmission (SILENT-300)

Quiet operation

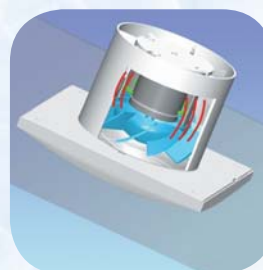

SILENT-300

In usual extract fans the vibrations are transmitted to the surrounding areas while in SILENT extractor fans the vibrations are absorbed by the Silent Blocks

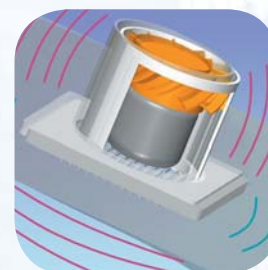

Usual extractor

Models features

	CZ	CRZ	CHZ	CZ PLUS	CRZ PLUS	CZ SILVER	CRZ SILVER	CHZ SILVER
Pilot light	•	•	•	•	•	•	•	•
Backdraft shutter	•	•	•	•	•	•	•	•
Adjustable Run-On-Timer (1-30min)		•	•		•		•	•
Adjustable humidistat			•					•
Ball bearings				•	•			
Silver colour						•	•	•

Technical characteristics

Model	Speed (r.p.m.)	Abs. power at free discharge (W)	Voltage (V) 50 Hz	Sound pressure level* (dB(A))	Airflow at free discharge (m ³ /h)	Insulation / IP	Weight (kg)
LENT-300	1700	29	230	32	280	II / IP45	1,25
SILENT-300 PLUS	2000	17	230	36	320	II / IP45	1,65

* Sound pressure level measured at 3 m at free air conditions.

■ Dimensions (mm)

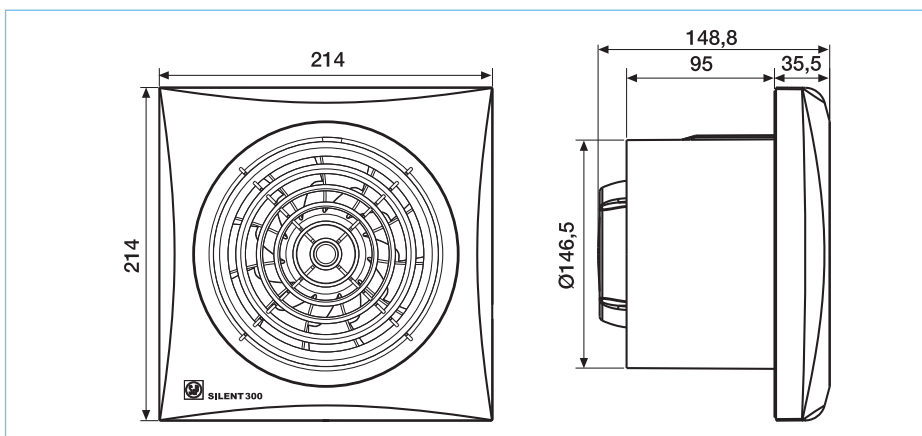

■ Performance curves

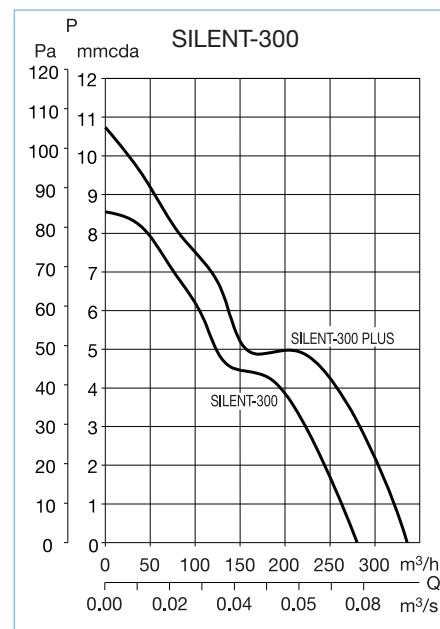

SILENT

Axial flow fans

■ Accessories



GSA-150
Flexible aluminium ducting



GRA-150
Aluminium exterior grille



PER-160W
Back draft shutter



CX-125/215
Worm drive ducting clip



REB
Single phase electronic speed controllers