



Gas burners two stages low emissions certified in conformity to CE 676 class 3 (Nox<80 mg/kWhs– CO<60mg/kWh),aluminum body, fan at high pressurisation, combustion head at elevated stability of flame, protection cover with noise reduction plate.

TECHNICAL DATA

MODEL		GAS X4/2CE-LX
Thermal power min 1° st./min 2° st.-max 2° st. *	Mcal/h	45/90-211
Thermal powe rmin 1° st./min 2° st.-max 2° st. *	kW	52/104-245
Delivery G20 (NATURAL GAS) min 1° st./min 2° st.-max 2° st.	Nm ³ /h	5,2/10,5-24,6
Fuel		NATURAL GAS (second family)
Combustible category		2R', 2H', 2L, 2E', 2E+, 2E', 2ELL', 2E(R)B
NOx	mg/kWh	<80 : class 3 (EN 676)
Intermittent operation (min. 1 stop every 24 hours)		double stage
Allowed enviroment conditions on running/stock		-15...+40°C / -20...+70°C, Relative umidity max 80%
Max temperature combustive air	°C	60
Min. pressure train D1" -S NATURAL GAS**	mbar	26
Maximum inlet pressure to the valves	mbar	360
Nominal electric power	W	260
Pump motor power	W	200
Power absorbed	A	1.1
Power supply		1/N~230V-50Hz
Degree of electric protection		IP40
Noisiness *** min-max	dba	66 - 68
Weight****	kg	17

* Condition of reference: Temperature environment 20°C - Barometric pressure 1013 mbars - Altitude 0 m o.l.s.

** Least pressure of feeding of the gas to the train to get the maximum power of the burner considering against pressure in chamber of value combustion 0 (zero)

*** Measured sonorous pressure in the laboratory combustion, with functional burner on beta boiler to 1 m of distance.

**** For burner with iron cover (F) add 2kgs to the weight.

OPERATING RANGE: Thermal power - Pressure in combustion chamber

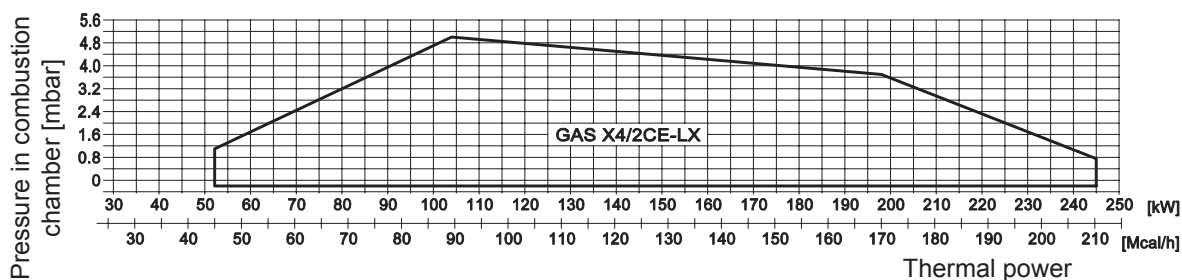

OVERALL DIMENSIONS (mm)

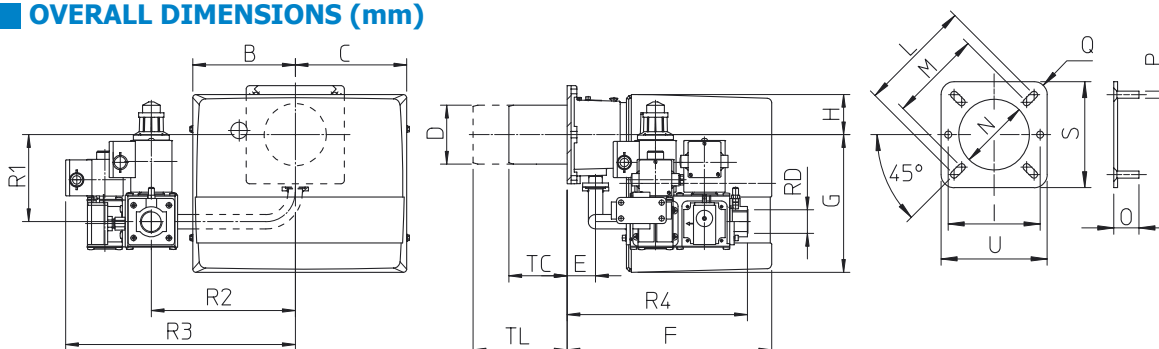

MODEL	B	C	D	E	F	G	H	I	L	M	N	O	P	Q	S	U	TC	TL	R1	R2	R3	R4	RD	Weight
GAS X4/2CE-LX-D1" -S	185	195	129	78	368	248	70	-	226	170	135	40	M10	R30	220	220	160	280	173	280	337	385	Rp 1	6 Kg