



BURNERS FOR GAS LOW NOX TWO STAGES PROGRESSIVE (HI-LOW FLAME) OR MODULATING



Gas burners two stages progressive (hi-low flame) or modulating (PID fully modulating) with the addition of the optional system modulation kit plus feeder, low emissions certified in conformity to CE 676 class 3 (Nox<80 mg/kWhs- CO<60mg/kWh), aluminum body, fan at high pressurisation, combustion head at elevated stability of flame, protection cover with noise reduction plate.

TECHNICAL DATA

MODEL		GAS 4X/MCE-LX
Thermal power min 1° st./min 2° st.-max 2° st. *	Mcal/h	45/90-211
Thermal power min 1° st./min 2° st.-max 2° st. *	kW	52/104-245
Delivery G20 (NATURAL GAS) min 1° st./min 2° st.-max 2° st.	Nm ³ /h	5,2/10,5-24,6
Fuel		NATURAL GAS (second family)
Combustible category		$I_{2R}, I_{2H}, I_{2L}, I_{2E}, I_{2E+}, I_{2E}, I_{2ELL}, I_{2E(R)B}$
NOx	mg/kWh	<80 : class 3 (EN 676)
Intermittent operation (min. 1 stop every 24 hours)		Two stages progressive or modulating
Allowed environment conditions on running/stock		-15...+40°C / -20...+70°C, Relative umidity max 80%
Max temperature combustive air	°C	60
Min. pressure train D1"-S NATURAL GAS**	mbar	26
Minimum pressure on the valve's inlet	mbar	360
Nominal electric power	W	260
Pump motor power	W	200
Power absorbed	A	1,1
Power supply		1/N~230V-50Hz
Degree of electric protection		IP40
Noisiness *** min-max	dBA	64 - 66
Weight****	kg	17

* Condition of reference: Temperature environment 20°C - Barometric pressure 1013 mbars - Altitude 0 m o.l.s.

** Least pressure of feeding of the gas to the train to get the maximum power of the burner considering against pressure in chamber of value combustion 0 (zero)

*** Measured sonorous pressure in the laboratory combustion, with functional burner on beta boiler to 1 m of distance.

**** For burner with iron cover (F) add 2kgs to the weight.

OPERATING RANGE: Thermal power - Pressure in combustion chamber

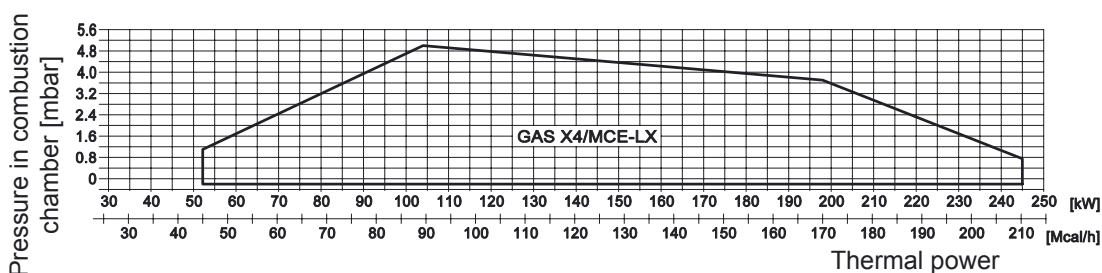

OVERALL DIMENSIONS (mm)

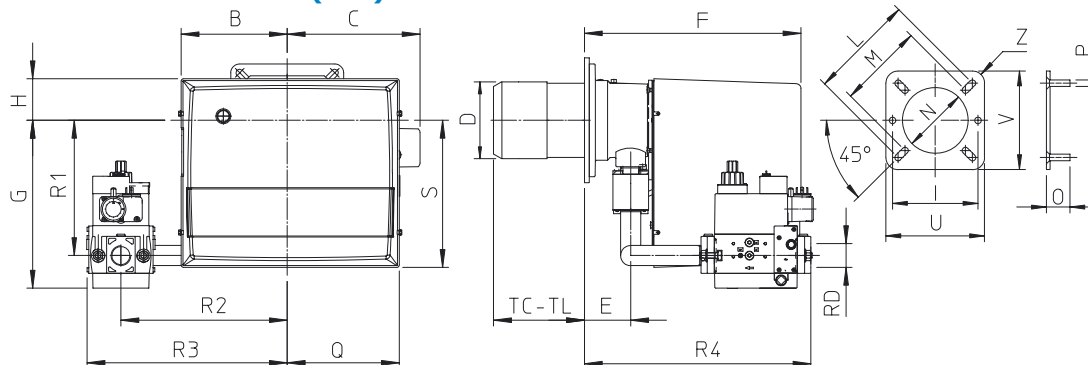

MODEL	B	C	D	E	F	G	H	I	L	M	N	O	P	Q	S	U	V	Z	TC	TL	R1	R2	R3	R4	RD	Train weight
GAS X4/MCE-LX-D1"-S	185	224	129	78	368	288	70	-	226	170	135	40	M10	190	248	220	220	R30	160	280	233	280	338	385	Rp 1	6 Kg