

PVHC/E-Series

Universal type Fan Coil Unit



We take care of your climate!

Distributeur:
CALOR SRL

Str. Progresului nr. 30-40, sector 5, Bucuresti
tel: 021.411.44.44, fax: 021.411.36.14
www.calorserv.ro - www.calor.ro

General Description

Determination of Right-hand/Left hand pipe connection.

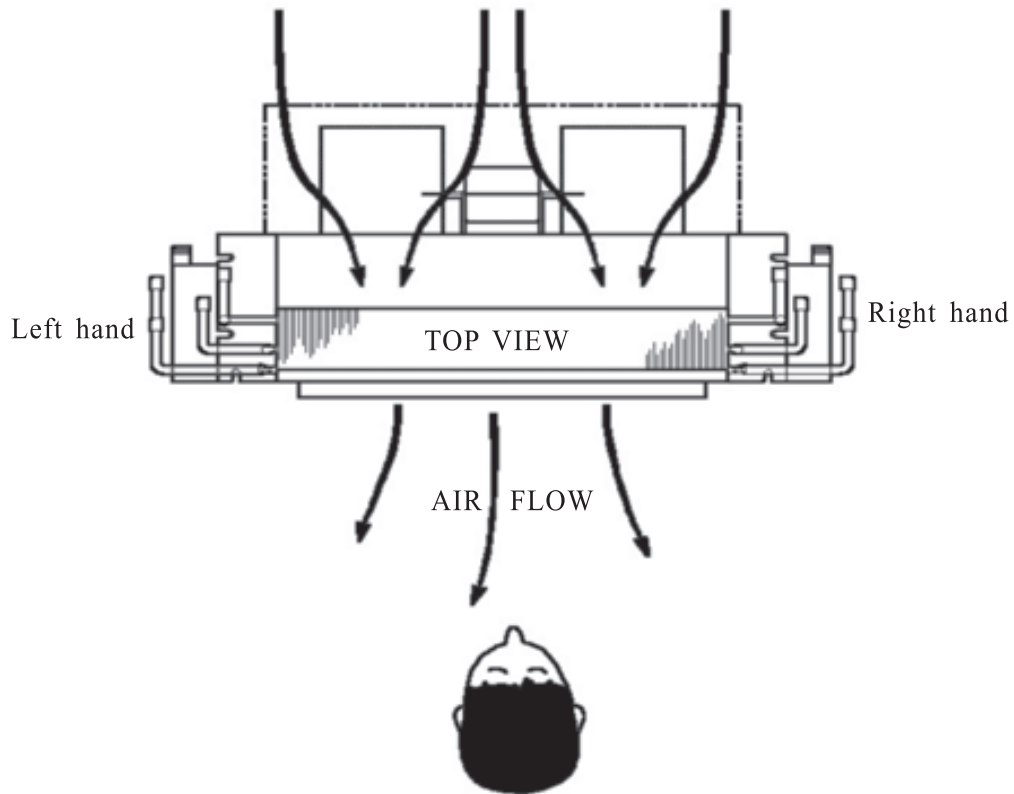

Universal type FCU

Model: PVHC/E

Introduction



PVHE



PVHC

The universal fan coil is designed for both vertical and horizontal installation. There are 2 versions, PVHE model is equip with cabinet decorated, and PVHC model is without cabinet.

Nomenclature

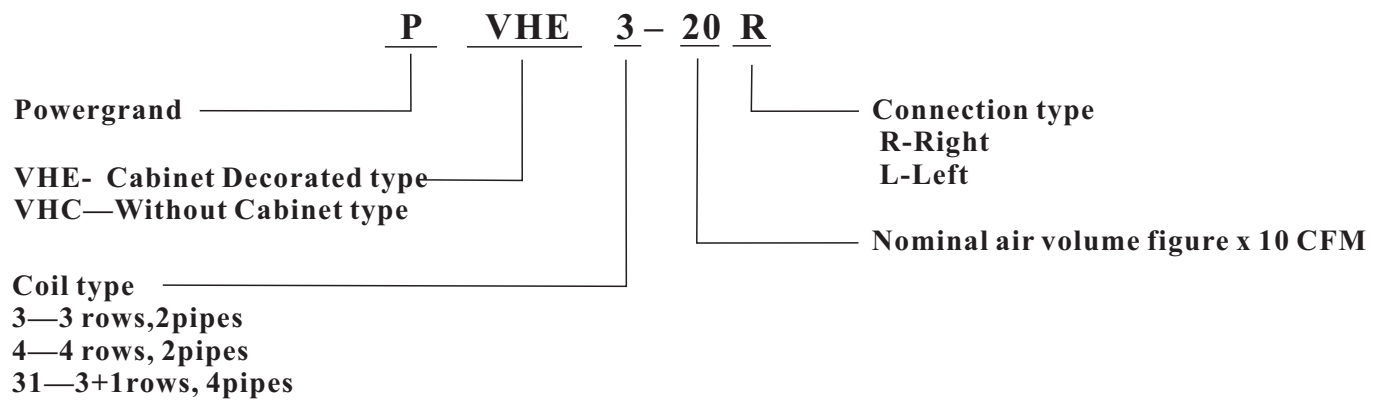

General Data

Spec			PVHC/E-20	PVHC/E-30	PVHC/E-40	PVHC/E-50	PVHC/E-60	PVHC/E-80	PVHC/E-100	PVHC/E-120	PVHC/E-140
Nominal Air volume	CFM		200	300	400	500	600	800	1000	1200	1400
Coil	Copper tube		3/8"(9.52mm)OD seamless copper tube								
	Fins		Hi-efficiency wavy corrugated aluminium blue fins								
	Fins per Inch	FPI	12	12	12	12	12	12	12	12	12
	Coil length	mm	445	520	635	735	835	1065	1285	1495	1600
	Coil height	mm	200	200	200	200	200	200	200	200	200
Fan	Fan type		Double inlet centrifugal forward curve, steel wheel,direct driven								
	Qty	pcs	1	2	2	2	2	3	4	4	4
Motor	Voltage		220-240V/1Ph/50-60HZ,110-127V/1Ph/50HZ								
	Motor speed		3 speed								
	Qty	pcs	1	1	1	1	1	2	2	2	2
Noise level at 1.0m distance	Max power input	W	42	58	65	83	94	114	138	184	221
	H	dB(A)	34	37	39	42	44	44	46	47	49
	M	dB(A)	28	29	33	35	38	39	41	42	45
	L	dB(A)	23	24	27	30	30	32	32	32	34
Water pipe	Cooling coil		3/4"FTP	3/4"FTP	3/4"FTP	3/4"FTP	3/4"FTP	3/4"FTP	3/4"FTP	3/4"FTP	3/4"FTP
	Heating coil (4 pipes unit)		3/4"FTP	3/4"FTP	3/4"FTP	3/4"FTP	3/4"FTP	3/4"FTP	3/4"FTP	3/4"FTP	3/4"FTP
Drain pipe			3/4"MTP	3/4"MTP	3/4"MTP	3/4"MTP	3/4"MTP	3/4"MTP	3/4"MTP	3/4"MTP	3/4"MTP
PVHC Package Dimension	L	mm	705	780	895	995	1095	1325	1545	1755	2100
	W	mm	600	600	600	600	600	600	600	600	600
	H	mm	260	260	260	260	260	260	260	260	260
PVHE Package Dimension	L	mm	908	958	1108	1258	1308	1658	1808	1958	2108
	W	mm	605	605	605	605	605	605	605	605	605
	H	mm	270	260	260	260	260	260	260	260	260
Net Weight	kg	18	19	21	23	24	34	37	45	48	

Universal type FCU

Model: PVHC/E

Performance Data

The performance data lists regular EU standard, ARI 440 standard and District Cooling. For more conditions, please refer to our selection software.

1. Standard rating

The following rating conditions are used:

Cooling: Entering air temperature: +27°C DB; +19.5°C WB
Water inlet/outlet: +7/12°C

Heating: Entering air temperature: +20°C DB
Water inlet temperature: +50°C

Water flow rate as for the cooling conditions.

3rows, 2pipes

Model			PVHC/E3-20	PVHC/E3-30	PVHC/E3-40	PVHC/E3-50	PVHC/E3-60	PVHC/E3-80	PVHC/E3-100	PVHC/E3-120	PVHC/E3-140
Air flow	H	CFM	242	300	400	517	587	758	1013	1248	1407
	M		184	255	301	403	424	524	670	1012	1112
	L		135	200	224	253	283	417	479	582	677
Total Cooling Capacity	H	K W	1.98	2.55	3.51	4.56	5.34	7.21	9.64	11.93	13.37
	M		1.64	2.28	2.89	3.84	4.25	5.54	7.16	10.28	11.31
	L		1.33	1.93	2.34	2.75	3.16	4.68	5.58	6.82	7.84
Sensible Cooling Capacity	H	K W	1.52	1.92	2.58	3.31	3.83	5.06	6.72	8.26	9.24
	M		1.24	1.69	2.08	2.75	2.99	3.83	4.91	7.06	7.75
	L		0.97	1.41	1.66	1.92	2.18	3.20	3.77	4.59	5.27
Heating Capacity	H	K W	2.46	3.10	4.16	5.28	6.06	7.95	10.47	12.79	14.26
	M		2.04	2.77	3.39	4.41	4.79	6.09	7.76	11.02	12.06
	L		1.61	2.31	2.71	3.12	3.54	5.12	6.04	7.31	8.35
Water Flow Rate	H	L/S	0.09	0.12	0.17	0.22	0.25	0.34	0.46	0.57	0.64
	M		0.08	0.11	0.14	0.18	0.20	0.26	0.34	0.49	0.54
	L		0.06	0.09	0.11	0.13	0.15	0.22	0.27	0.33	0.37
Water Pressure Drop	H	K pa	2.58	4.21	7.86	12.80	17.92	33.86	59.86	92.21	114.52
	M		2.03	3.64	6.07	10.21	13.24	23.95	40.51	75.79	91.25
	L		1.53	2.93	4.61	6.59	8.99	19.18	29.20	44.24	56.80

4rows, 2pipes

Model			PVHC/E4-20	PVHC/E4-30	PVHC/E4-40	PVHC/E4-50	PVHC/E4-60	PVHC/E4-80	PVHC/E4-100	PVHC/E4-120	PVHC/E4-140
Air flow	H	CFM	235	291	388	501	570	735	983	1210	1365
	M		178	247	292	391	411	509	650	982	1079
	L		131	194	218	245	274	404	465	564	657
Total Cooling Capacity	H	K W	2.44	3.12	4.27	5.52	6.44	8.63	11.51	14.22	15.92
	M		2.02	2.78	3.49	4.63	5.09	6.58	8.48	12.20	13.41
	L		1.61	2.34	2.80	3.27	3.74	5.51	6.54	7.97	9.17
Sensible Cooling Capacity	H	K W	1.78	2.24	3.02	3.88	4.47	5.90	7.83	9.64	10.78
	M		1.43	1.97	2.41	3.19	3.46	4.40	5.65	8.19	8.99
	L		1.11	1.62	1.90	2.19	2.48	3.65	4.28	5.21	6.01
Heating Capacity	H	K W	2.86	3.56	4.72	6.02	6.93	9.05	11.92	14.57	16.25
	M		2.32	3.13	3.83	5.00	5.40	6.82	8.69	12.46	13.64
	L		1.82	2.60	3.02	3.48	3.92	5.68	6.65	8.05	9.25
Water Flow Rate	H	L/S	0.12	0.15	0.20	0.26	0.31	0.41	0.55	0.68	0.76
	M		0.10	0.13	0.17	0.22	0.24	0.31	0.40	0.58	0.64
	L		0.08	0.11	0.13	0.16	0.18	0.26	0.31	0.38	0.44
Water Pressure Drop	H	K pa	2.56	4.01	7.13	11.21	15.31	27.71	47.15	70.26	86.50
	M		2.04	3.50	5.60	9.08	11.55	20.03	32.72	58.84	70.48
	L		1.56	2.84	4.31	5.99	7.99	16.21	23.98	35.38	44.78

The following rating conditions are used:

Cooling: Entering air temperature: +27°C DB; +19.5°C WB
Water inlet/outlet: +7/12°C

Heating: Entering air temperature: +20°C DB
Water inlet/outlet: +70°C/60°C

3+1rows, 4pipes

Model			PVHC/E31-20	PVHC/E31-30	PVHC/E31-40	PVHC/E31-50	PVHC/E31-60	PVHC/E31-80	PVHC/E31-100	PVHC/E31-120	PVHC/E31-140
Air flow	H	CFM	235	291	388	501	270	735	983	1210	1365
	M		178	247	292	391	411	509	650	982	1079
	L		131	194	218	245	274	404	465	564	657
Total Cooling Capacity	H	K W	1.96	2.53	3.49	4.52	5.30	7.14	9.56	11.83	13.26
	M		1.63	2.26	2.86	3.80	4.19	5.46	7.06	10.17	11.18
	L		1.31	1.91	2.31	2.71	3.11	4.60	5.48	6.70	7.70
Sensible Cooling Capacity	H	K W	1.39	1.75	2.37	3.04	3.51	4.64	6.17	7.59	8.50
	M		1.12	1.55	1.90	2.51	2.73	3.49	4.48	6.47	7.10
	L		0.88	1.28	1.51	1.74	1.98	2.91	3.42	4.17	4.80
Heating Capacity	H	K W	1.61	2.06	2.82	3.63	4.25	5.73	7.59	9.35	10.43
	M		1.37	1.87	2.37	3.12	3.47	4.55	5.86	8.21	9.01
	L		1.13	1.61	1.97	2.33	2.69	3.93	4.72	5.76	6.56
Cooling Water Flow Rate	H	L/S	0.09	0.12	0.17	0.22	0.25	0.34	0.46	0.56	0.63
	M		0.08	0.11	0.14	0.18	0.20	0.26	0.34	0.49	0.53
	L		0.06	0.09	0.11	0.13	0.15	0.22	0.26	0.32	0.37
Cooling Water Pressure Drop	H	K pa	2.56	4.17	7.78	12.67	17.71	33.46	59.18	91.19	113.34
	M		2.00	3.60	5.98	10.08	13.04	23.54	39.78	74.68	90.62
	L		1.51	2.88	4.52	6.45	8.79	18.77	28.53	43.21	55.54
Heating Water Flow Rate	H	L/S	0.04	0.05	0.07	0.09	0.10	0.14	0.18	0.22	0.25
	M		0.03	0.04	0.06	0.07	0.08	0.11	0.14	2.00	0.22
	L		0.03	0.04	0.05	0.06	0.06	0.09	0.11	0.14	0.16
Heating Water Pressure Drop	H	K pa	0.36	0.60	1.12	1.83	2.58	4.95	8.79	13.29	16.88
	M		0.29	0.52	0.89	1.49	1.96	3.61	6.16	11.37	13.83
	L		0.22	0.43	0.69	1.00	1.38	2.96	4.59	7.00	8.96

Universal type FCU

Model: PVHC/E

Performance Data

2. ARI-440 Standard rating

The following rating conditions are used:

Cooling: Entering air temperature: +80°F DB; +67°F WB
Water inlet/outlet: +45/55°F

Heating: Entering air temperature: +68°F DB
Water inlet temperature: +140°F

Water flow rate as for the cooling conditions.

3rows, 2pipes

Model			PVHC/E3-20	PVHC/E3-30	PVHC/E3-40	PVHC/E3-50	PVHC/E3-60	PVHC/E3-80	PVHC/E3-100	PVHC/E3-120	PVHC/E3-140
Air flow	H	CFM	242	300	400	517	587	758	1013	1248	1407
	M		184	255	301	403	424	524	670	1012	1112
	L		135	200	224	253	283	417	479	582	677
Total Cooling Capacity	H	Btu/h	6041	7850	10956	14300	16826	22901	30717	38157	42765
	M		5051	7065	9044	12082	13447	17645	22935	32935	36246
	L		4130	6007	7372	8703	10068	14949	17952	21980	25256
Sensible Cooling Capacity	H	Btu/h	4846	6143	8294	10683	12355	16417	21809	26860	30034
	M		3959	5427	6724	8874	9659	12423	15939	22969	25222
	L		3106	4505	5358	6212	7065	10376	12287	14949	17202
Heating Capacity	H	Btu/h	10922	13618	18294	23277	26860	35461	46690	57065	63618
	M		8806	12150	14847	19522	21331	34676	49318	53960	
	L		7065	10307	11980	13891	15836	22935	27031	32731	37441
Water Flow Rate	H	Gpm	1.27	1.59	2.22	2.85	3.33	4.60	6.18	7.61	8.56
	M		0.95	1.43	1.74	2.38	2.69	3.49	4.60	6.66	7.29
	L		0.79	1.27	1.43	1.74	2.06	3.01	3.65	4.44	5.07
Water Pressure Drop	H	ftH ₂ O	0.66	1.09	2.06	3.38	4.76	9.09	16.16	24.97	31.06
	M		0.52	0.95	1.60	2.71	3.54	6.47	11.00	20.58	25.00
	L		0.40	0.77	1.22	1.76	2.42	5.20	7.97	12.11	15.54

4rows, 2pipes

Model			PVHC/E4-20	PVHC/E4-30	PVHC/E4-40	PVHC/E4-50	PVHC/E4-60	PVHC/E4-80	PVHC/E4-100	PVHC/E4-120	PVHC/E4-140
Air flow	H	CFM	235	291	388	501	570	735	983	1210	1365
	M		178	247	292	391	411	509	650	982	1079
	L		131	194	218	245	274	404	465	564	657
Total Cooling Capacity	H	Btu/h	7577	9761	13481	17475	20478	27645	36963	45768	51263
	M		6314	8737	11058	14710	16246	21161	27372	39386	43345
	L		5085	7372	8942	10478	12014	17816	21195	25905	29830
Sensible Cooling Capacity	H	Btu/h	5700	7201	9727	12526	14505	19181	25495	31400	35154
	M		4608	6348	7782	10341	11229	14335	18430	26724	29318
	L		3584	5222	6143	7099	8055	11877	13993	17065	19659
Heating Capacity	H	Btu/h	12628	15597	20990	26758	30854	40478	53345	65257	72799
	M		10205	13891	16997	22355	24198	30649	39079	55905	61229
	L		7952	11502	13447	15461	17509	25563	29932	36246	41639
Water Flow Rate	H	Gpm	1.59	1.90	2.69	3.49	4.12	5.55	7.45	9.19	10.30
	M		1.27	1.74	2.22	3.01	3.33	4.28	5.55	7.93	8.72
	L		0.95	1.43	1.74	2.06	2.38	3.65	4.28	5.23	6.02
Water Pressure Drop	H	ftH ₂ O	0.68	1.08	1.94	3.06	4.20	7.66	13.09	19.66	24.10
	M		0.55	0.95	1.53	2.49	3.19	5.57	9.14	16.43	19.71
	L		0.42	0.77	1.19	1.66	2.22	4.53	6.74	9.96	12.60

The following rating conditions are used:

Cooling: Entering air temperature: +80°F DB; +67°F WB
Water inlet/outlet: +45/55°F

Heating: Entering air temperature: +68°F DB
Water inlet/outlet: +180°F / +140°F

3+1rows, 4pipes

Model			PVHC/E31-20	PVHC/E31-30	PVHC/E31-40	PVHC/E31-50	PVHC/E31-60	PVHC/E31-80	PVHC/E31-100	PVHC/E31-120	PVHC/E31-140
Air flow	H	CFM	235	291	388	501	270	735	983	1210	1365
	M		178	247	292	391	411	509	650	982	1079
	L		131	194	218	245	274	404	465	564	657
Total Cooling Capacity	H	Btu/h	6007	7816	10887	14198	16724	22696	30512	37884	42492
	M		5017	6997	8976	11980	13311	17440	22662	32628	35905
	L		4061	5939	7270	8601	9898	14744	17645	21638	24881
Sensible Cooling Capacity	H	Btu/h	4437	5631	7611	9795	11331	15051	20034	24676	27645
	M		3584	4949	6109	8123	8840	11331	14574	21058	23106
	L		2833	4096	4846	5631	6416	9454	11161	13584	15632
Heating Capacity	H	Btu/h	4061	5529	8055	10717	12935	18260	24813	31127	34949
	M		3515	5051	6860	9317	10717	14676	19386	27475	30376
	L		3003	4437	5802	7099	8430	12765	15768	19556	22389
Cooling Water Flow Rate	H	Gpm	1.27	1.59	2.22	2.85	3.33	4.60	6.18	7.61	8.56
	M		0.95	1.43	1.74	2.38	2.69	3.49	4.60	6.50	7.29
	L		0.79	1.27	1.43	1.74	2.06	3.01	3.49	4.28	5.07
Cooling Water Pressure Drop	H	ftH ₂ O	0.66	1.08	2.04	3.35	4.72	9.00	16.00	24.74	30.78
	M		0.52	0.94	1.58	2.68	3.50	6.37	10.82	20.32	24.69
	L		0.39	0.76	1.20	1.73	2.37	5.10	7.80	11.85	15.23
Heating Water Flow Rate	H	Gpm	0.16	0.32	0.48	0.48	0.63	0.95	1.27	1.59	1.74
	M		0.16	0.32	0.32	0.48	0.48	0.79	0.95	1.43	1.59
	L		0.16	0.16	0.32	0.32	0.48	0.63	0.79	0.95	1.11
Heating Water Pressure Drop	H	ftH ₂ O	0.03	0.05	0.10	0.17	0.25	0.51	0.93	1.48	1.85
	M		0.02	0.04	0.08	0.14	0.19	0.37	0.66	1.24	1.53
	L		0.02	0.04	0.06	0.10	0.14	0.31	0.50	0.78	1.01

Universal type FCU

Model: PVHC/E

Performance Data

3. District Cooling Standard rating

The following rating conditions are used:

Cooling: Entering air temperature: +24.4°CDB; +17.2°C WB

Water inlet/outlet: +5.5/14.4°C

4rows, 2pipes

Model		PVHC/E4-20	PVHC/E4-30	PVHC/E4-40	PVHC/E4-50	PVHC/E4-60	PVHC/E4-80	PVHC/E4-100	PVHC/E4-120	PVHC/E4-140
Air flow	H	235	291	388	501	570	735	983	1210	1365
	M	178	247	292	391	411	509	650	982	1079
	L	131	194	218	245	274	404	465	564	657
Total Cooling Capacity	H	1.31	1.71	2.35	3.16	3.84	5.46	7.50	9.45	10.65
	M	1.08	1.52	2.00	2.73	3.15	4.32	5.73	8.26	9.14
	L	0.85	1.28	1.67	2.05	2.42	3.71	4.56	5.66	6.52
Sensible Cooling Capacity	H	1.29	1.68	2.31	3.01	3.52	4.75	6.38	7.92	8.88
	M	1.06	1.50	1.86	2.50	2.75	3.58	4.65	6.76	7.45
	L	0.83	1.23	1.48	1.74	2.00	2.99	3.57	4.38	5.05
Water Flow Rate	H	0.04	0.05	0.06	0.08	0.10	0.15	0.20	0.25	0.29
	M	0.03	0.04	0.05	0.07	0.08	0.12	0.15	0.22	0.25
	L	0.02	0.03	0.04	0.05	0.07	0.10	0.12	0.15	0.17
Water Pressure Drop	H	0.61	0.98	1.75	2.89	4.14	8.05	14.18	21.77	26.86
	M	0.48	0.85	1.44	2.43	3.27	6.08	10.29	18.51	22.39
	L	0.36	0.69	1.17	1.72	2.39	5.06	7.82	11.78	14.93

Dimensional Data

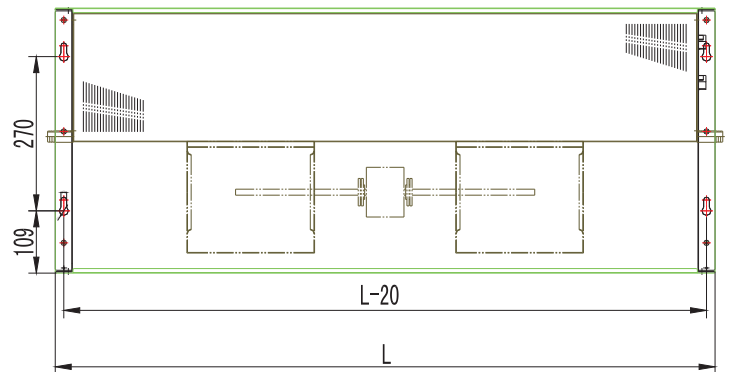
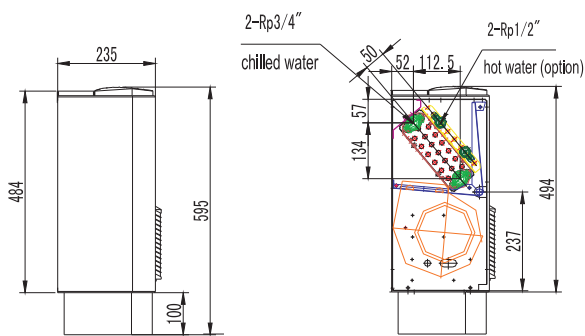
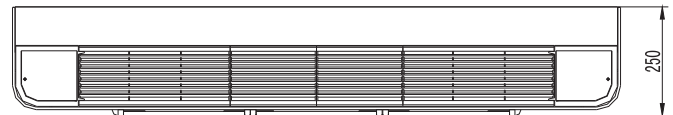
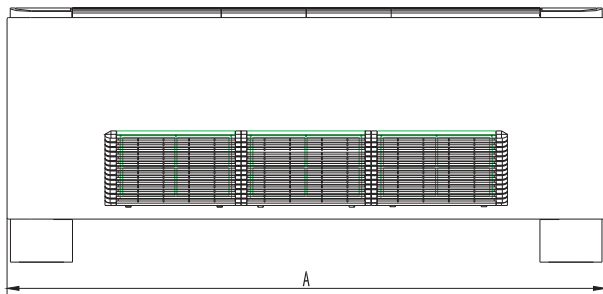

PVHE

Model	PVHE-20	PVHE-30	PVHE-40	PVHE-50	PVHE-60	PVHE-80	PVHE-100	PVHE-120	PVHE-140
L	598	658	808	958	1008	1358	1508	1658	1808
A	858	908	1058	1208	1258	1608	1758	1908	2058

Universal type FCU

Model: PVHC/E

Dimensional Data

Spec	A	B	C
PVHC-20	640	614	590
PVHC-30	740	714	690
PVHC-40	840	814	790
PVHC-50	940	914	890
PVHC-60	1070	1044	1020
PVHC-80	1390	1364	1340
PVHC-100	1590	1564	1540
PVHC-120	1800	1774	1750
PVHC-140	1900	1874	1850

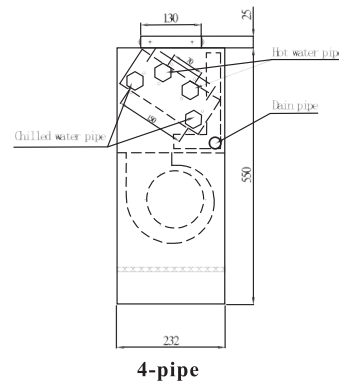
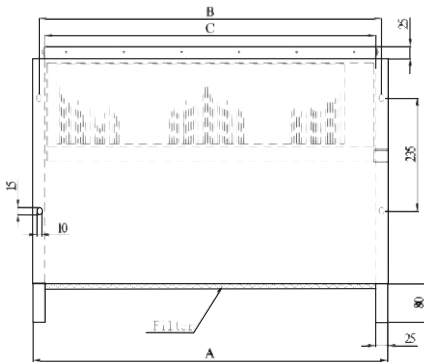

PVHC

Wiring Diagrams

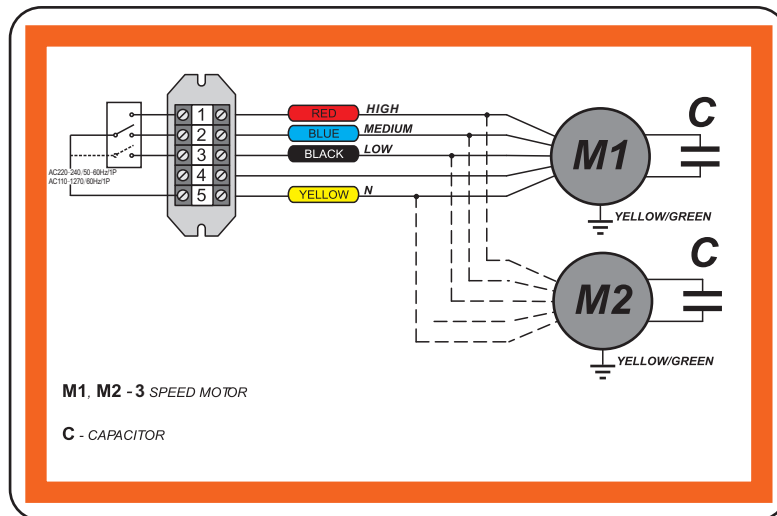

Option Accessories

1. Valve packages

Factory installed 2-way or 3-way valves for 2-pipe and 4-pipe system. Basic package includes ball valve, motorized valve, and connector.

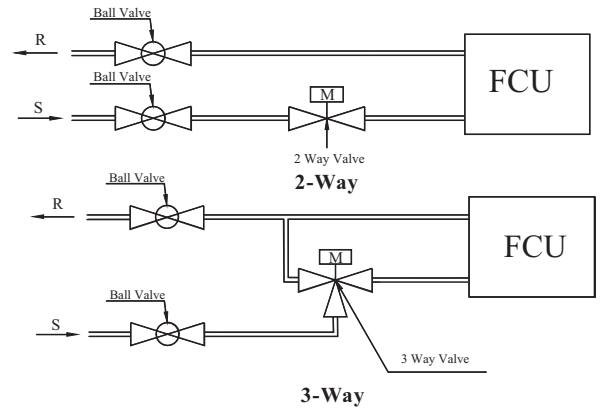

2. Auxiliary drain pan

Auxiliary is especially for condensate water from valve package; powder coating housing with insulation.

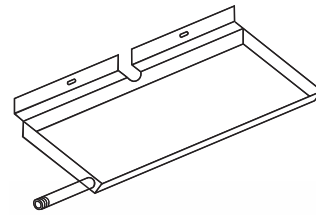

3. Electric Heater

- Electric Heater made of PTC martial. High safety (with the rising of temperature, the current is decreasing)
- Internal wiring rated at 105°C , automatic rest
- Silent solid state relays
- Manual rest secondary limits is for option



4. Mechanical Thermostat

Cool and Heat mode

Room temperature setting

- Three selectable fan speeds
- Motorized valve control



TC2000J(2 pipes)
TC2002J(4 pipes)

5. Electronic LCD Thermostat

- LCD display, detect and display room temperature
- Cool, heat, and vent mode
- Auto-random restart and parameters memory set in case of power failure
- Weekly timer setting
- Remote Control(Optional)



TC08L8 (2 pipes)
TC08L8CV2(4 pipes)

6. Motorized Valve

- Conform with the European pressure equipment directive PED 97/23/EC
- Actuators conform with the protection requirements of council directive 89/336/EEC
- Forging brass body
- Efficient power consumption and less noise



Vb5471 (2-Way)



Vb5871(3-Way)

7. Spring hanger

Use for hanger the FCU to the ceiling. Rubber and spring composed together to absorb vibration of the FCU. Reduce the noise effectively.



Model: SHF