

HIGH POWER

TECHNICAL SHEET



VICTRIX 90 VICTRIX 115

Wall-hung condensing boilers
for high power





VICTRIX 90 is the new wall-hung condensing boiler for room heating only, set-up for independent functioning and for that in cascade mode (up to 3 appliances), with the advantage of guaranteeing particularly high total performance and reduced running costs. Condensation technology allows to obtain high performance. The high potentiality of VICTRIX 90 is ideal for heating large residential heating systems (e.g. condominiums) and for commercial and industrial applications. In the case of installation of an individual boiler, and external 3-way valve can be connected for coupling to a separate storage tank unit for the production of DHW. A hydraulic manifold can also be connected in order to increase the circulation in the system with consequent flexibility and speed of installation. When functioning in cascade mode, appropriate distribution manifolds can be connected via threaded systems. The special ecological burner guarantees particularly reduced polluting emissions (the boiler belongs to the most environment-friendly class envisioned by European Standards - class 5).

1

VICTRIX 90 FEATURES

Condensing wall-hung open chamber fan assisted premix boiler with high efficiency and forced circulation, 90kW (77,400 kcal/h). Type-approved for installation in heating control unit and outside the building, it can be used in two configurations:

Open chamber and fan assisted (the boiler is supplied as per standard in configuration B₂₃);

Sealed chamber and fan-assisted (appliance type C), only if installed using vertical or horizontal concentric kits.

The boiler is made up from:

- total premix combustion system with metal fibre multigas burner, complete with ignition electrode and detection electrode;
- pneumatic gas valve with double shutter;
- primary gas/water heat exchanger with stainless steel double coil, composed of 16 elements (10+6 flue side);
- combustion chamber in stainless steel internally isolated using ceramic panels;
- fan with electronically variable speed;
- circuit for disposal of condensate including trap and flexible discharge pipe;
- hydraulic unit comprising primary circuit pressure switch, circulation pump and automatic air vent valve;
- 4 bar safety valve (ISPESL type-approved) and draining funnel as per standard, heating system manometer;
- over-temperature safety thermostat;
- flue probe;
- control panel supplied with P.C.B. with microprocessor with continuous flame modulation on heating with P.I.D. control, modulation field from 90 to 22.5 kW (from 77,400 to 19,350 kcal/h);
- system flow regulation probe;
- system return regulation probe;
- adjustable central heating flow temperature with factory setting from 25 to 85°C;

- ignition delay device in central heating phase, anti-freeze protection, pump anti-blocking function, chimney sweep function;
- setting and regulation of the boiler functioning parameters using keys with display of status and operating mode by means of a 4-digit display;
- self-diagnosis system with digital display of the temperature, functioning status and error codes;
- IPX5D electrical insulation level, with possibility of installation outside without any additional protection (in the open);
- anti-freeze protection to -5 °C as per standard (-15 °C with relevant kit optional);
- set-up for the connection of the cascade and zone regulator and of the external probe;
- set-up for connection to an external 3-way valve, for coupling to a separate storage tank unit for the production of DHW;
- set-up for functioning in cascade mode (up to 3 boilers with a unique ISPESL safety devices kit);
- set-up for the installation of the ISPESL-approved safety stub pipes, both in single and set configuration (up to 3 boilers).

Supplied complete with sample points for combustion analysis and gas interception cocks.

Category II_{2H3D} appliance, functions with natural gas and L.P.G. CE marking.

is available in the model:

• **VICTRIX 90**

code 3.020425

NOTA BENE: for correct installation of the boiler the Immergas "Green Range" air intake/fumes exhaust kit must be used and however, dedicated for the VICTRIX 90 boiler, whether in single or cascade configuration (set).

VICTRIX 90 - 115



VICTRIX 115 is the new wall-hung condensing boiler for room heating only, set-up for independent functioning and for that in cascade mode (up to 3 appliances), with the advantage of guaranteeing particularly high total performance and reduced running costs. Condensation technology allows to obtain particularly high performance. The high potentiality of VICTRIX 115 is ideal for heating large residential heating systems (e.g. condominiums) and for commercial and industrial applications. In the case of installation of an individual boiler, and external 3-way valve can be connected for coupling to a separate storage tank unit for the production of DHW. A hydraulic manifold can also be connected in order to increase the circulation in the system with consequent flexibility and speed of installation. When functioning in cascade mode, appropriate distribution manifolds can be connected via threaded systems. The special ecological burner guarantees particularly reduced polluting emissions (the boiler belongs to the most environment-friendly class envisioned by European Standards - class 5).

2

VICTRIX 115 FEATURES

Condensing wall-hung open chamber fan assisted premix boiler with high efficiency and forced circulation, 111kW (95,460 kcal/h). Type-approved for installation in heating control unit and outside the building, it can be used in two configurations:

Open chamber and fan assisted (the boiler is supplied as per standard in configuration B₂₃);

Sealed chamber and fan-assisted (appliance type C), only if installed using vertical or horizontal concentric kits.

The boiler is made up from:

- total premix combustion system with metal fibre multigas burner, complete with ignition electrode and detection electrode;
- gas valve with double shutter;
- primary gas/water heat exchanger with stainless steel double coil, composed of 18 elements (12+6 flue side);
- combustion chamber in stainless steel internally isolated using ceramic panels;
- fan with electronically variable speed;
- circuit for disposal of condensate including trap and flexible discharge pipe;
- hydraulic unit composed of primary circuit pressure switch, circulation pump and automatic air vent valve;
- 4 bar safety valve (ISPESL type-approved) and draining funnel as per standard, heating system manometer;
- over-temperature safety thermostat;
- flue probe;
- control panel supplied with P.C.B. with microprocessor with continuous flame modulation on heating with P.I.D. control, modulation field from 111 to 29.5 kW (from 95,460 to 23,370 kcal/h);
- system flow regulation probe;
- system return regulation probe;
- adjustable central heating flow temperature with factory setting from 25 to 85°C;

- ignition delay device in central heating phase, anti-freeze protection, pump anti-blocking function, chimney sweep function;
- setting and regulation of the boiler functioning parameters using keys with display of status and operating mode by means of a 4-digit display;
- self-diagnosis system with digital display of the temperature, functioning mode and error codes by means of the display, always available;
- IPX5D electrical insulation level, with possibility of installation outside without any additional protection (in the open);
- anti-freeze protection to -5 °C as per standard (-15 °C with relevant kit optional);
- set-up for the connection of the cascade and zone regulator and of the external probe;
- set-up for connection to an external 3-way valve, for coupling to a separate storage tank unit for the production of DHW;
- set-up for functioning in cascade mode (up to 3 boilers with a unique ISPESL safety devices kit);
- set-up for the installation of the ISPESL-approved safety stub pipes, both in single and set configuration (up to 3 boilers).

Supplied complete with sample points for combustion analysis and gas interception cocks.

Category II _{2H3P} appliance, functions with natural gas and L.P.G. CE marking.

is available in the model:

• **VICTRIX 115**

code 3.020426

NOTA BENE: for correct installation of the boiler the Immergas "Green Range" air intake/fumes exhaust kit must be used and however, dedicated for the VICTRIX 115 boiler, whether in single or cascade configuration (set).



3 REPRESENTATIVE PLANT LAYOUT WITH SOLAR SYSTEM

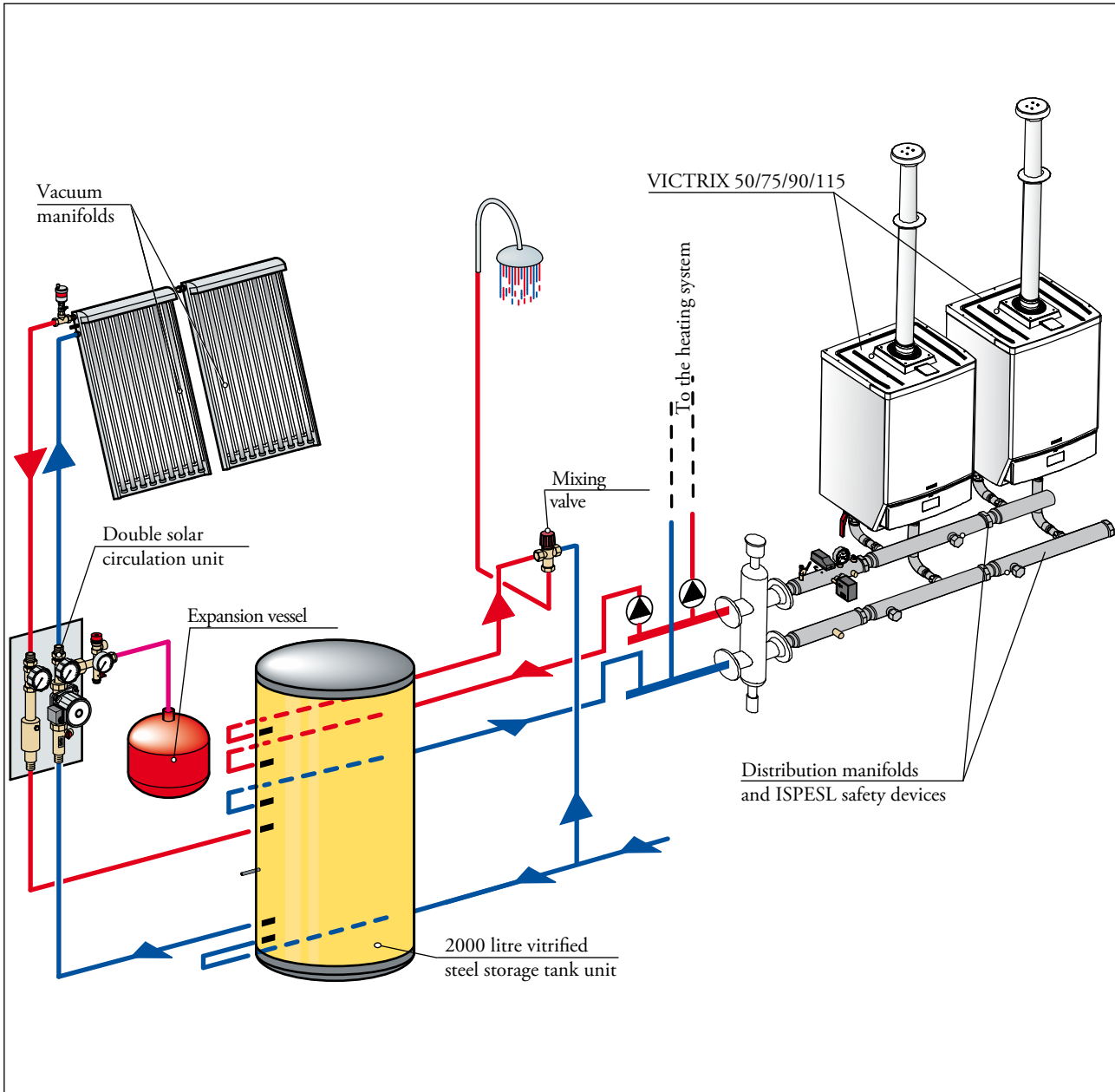

Both in the case of single installation or in sets, the set-up for coupling with a separate storage tank unit are supplied with relevant kits, available in the 200, 300, 500, 1000, 1500 and 2000 litre versions. The Storage Tank units are equipped with double coil for heat exchange. They are designed for

coupling to Immergas solar solutions for the production of hot water in large houses or condominiums, as well as sport structures and hotels.

VICTRIX 90 - 115

4 VICTRIX 90 MAIN COMPONENTS

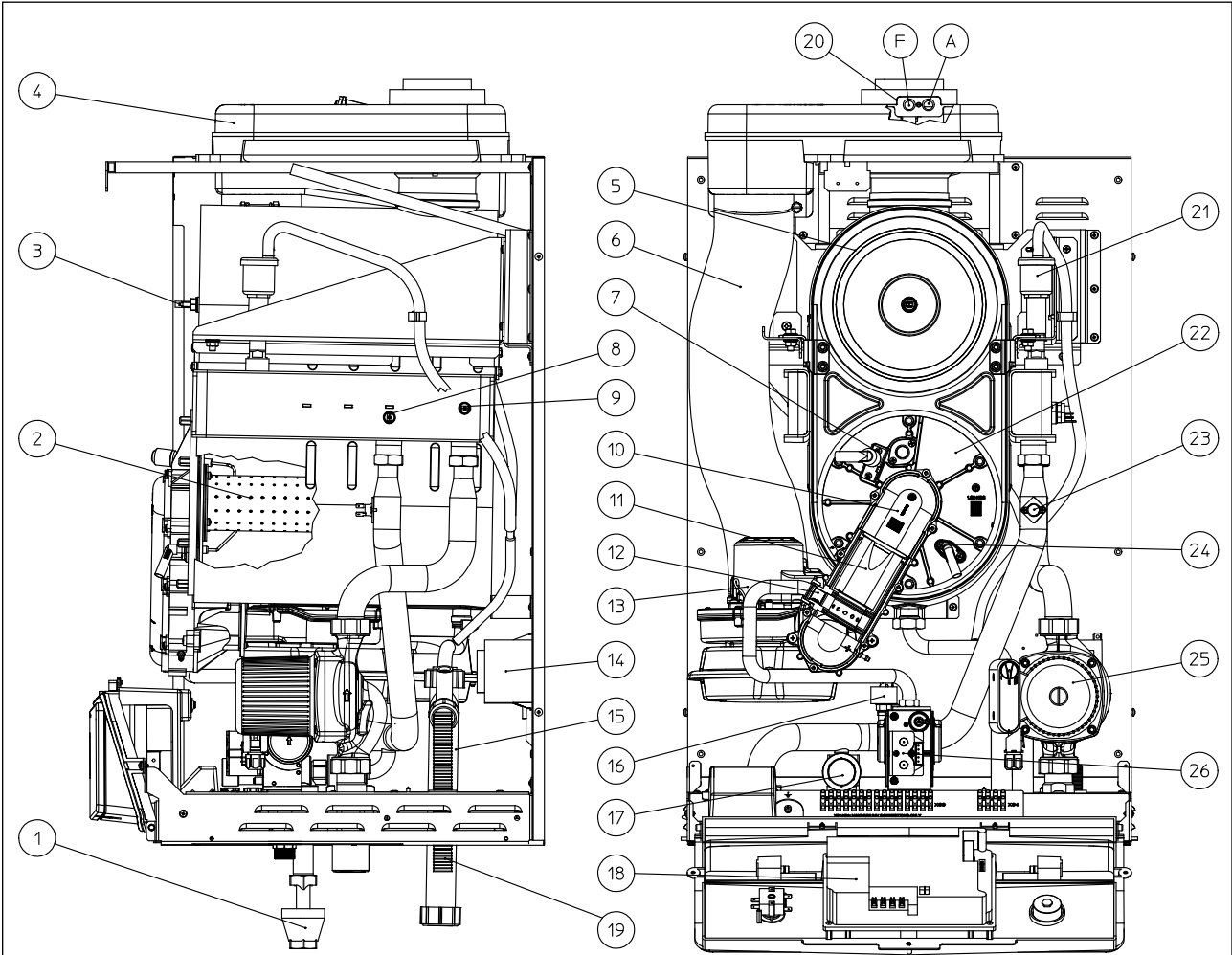

KEY:

- | | |
|--|---|
| 1 - Draining funnel | 14 - Current transformer |
| 2 - Burner | 15 - Condensate drain trap |
| 3 - Flue probe | 16 - Absolute pressure switch |
| 4 - Flue hood | 17 - 4 bar safety valve |
| 5 - Condensation module | 18 - P.C.B. |
| 6 - Air intake pipe | 19 - Condensate drain pipe |
| 7 - Ignition electrode | 20 - Sample points (air A) - (flue gases F) |
| 8 - System flow regulation NTC probe | 21 - Air vent valve |
| 9 - System return regulation NTC probe | 22 - Condensation module cover |
| 10 - Sleeve with seats for Venturi | 23 - Over-heating safety thermostat |
| 11 - Venturi | 24 - Detection electrode |
| 12 - Gas nozzle | 25 - Pump |
| 13 - Air fan | 26 - Gas valve |



5

VICTRIX 115 MAIN COMPONENTS

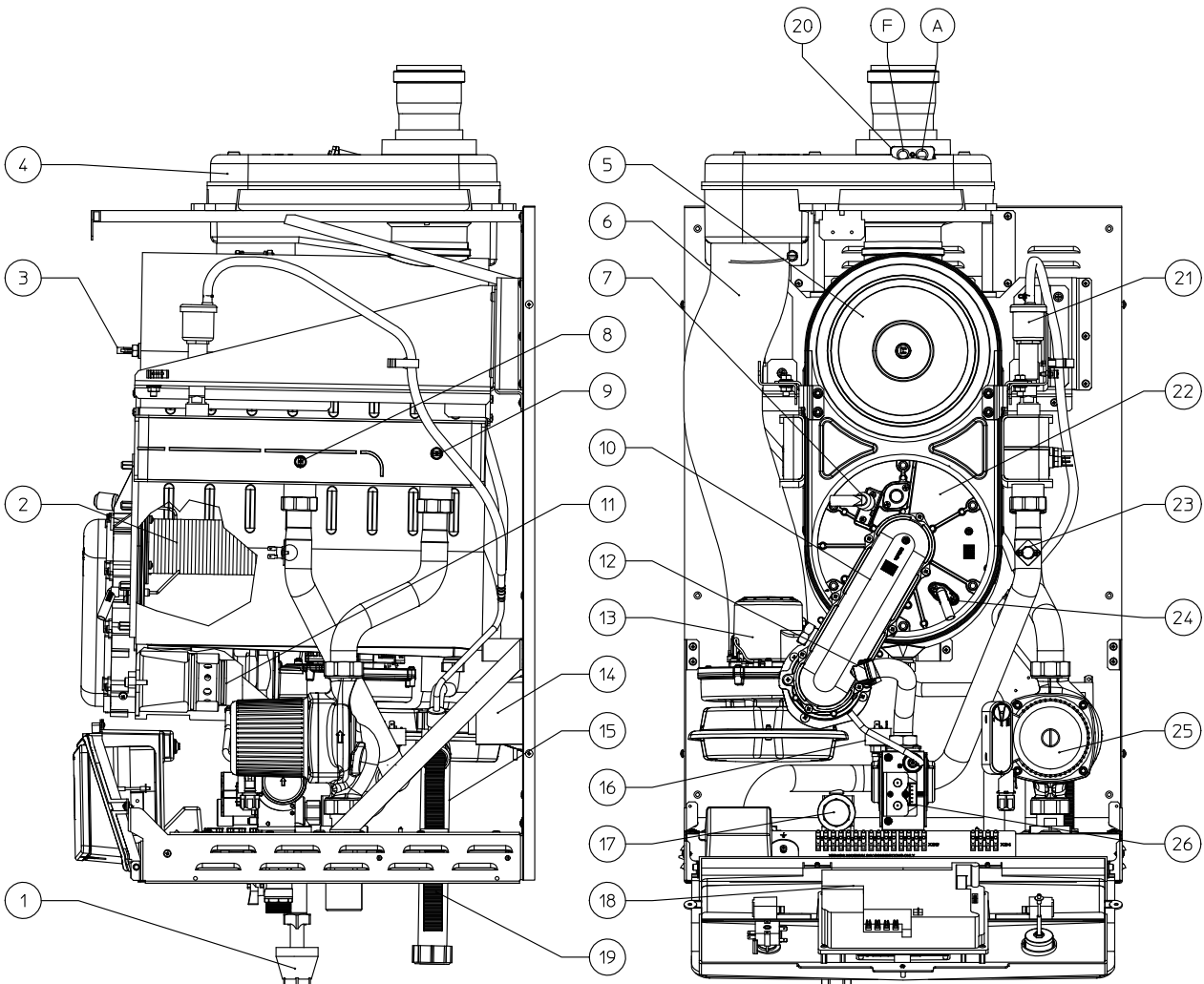

KEY:

- | | |
|--|---|
| 1 - Draining funnel | 14 - Current transformer |
| 2 - Burner | 15 - Condensate drain trap |
| 3 - Flue probe | 16 - Absolute pressure switch |
| 4 - Flue hood | 17 - 4 bar safety valve |
| 5 - Condensation module | 18 - P.C.B. |
| 6 - Air intake pipe | 19 - Condensate drain pipe |
| 7 - Ignition electrode | 20 - Sample points (air A) - (flue gases F) |
| 8 - System flow regulation NTC probe | 21 - Air vent valve |
| 9 - System return regulation NTC probe | 22 - Condensation module cover |
| 10 - Sleeve with seats for Venturi | 23 - Over-heating safety thermostat |
| 11 - Venturi | 24 - Detection electrode |
| 12 - Gas nozzle | 25 - Pump |
| 13 - Air fan | 26 - Gas valve |

VICTRIX 90 - 115

6 MAIN DIMENSIONS

Model	Height mm	Width mm	Depth mm
VICTRIX 90 - 115	1010	600	610

6.1 CONNECTIONS

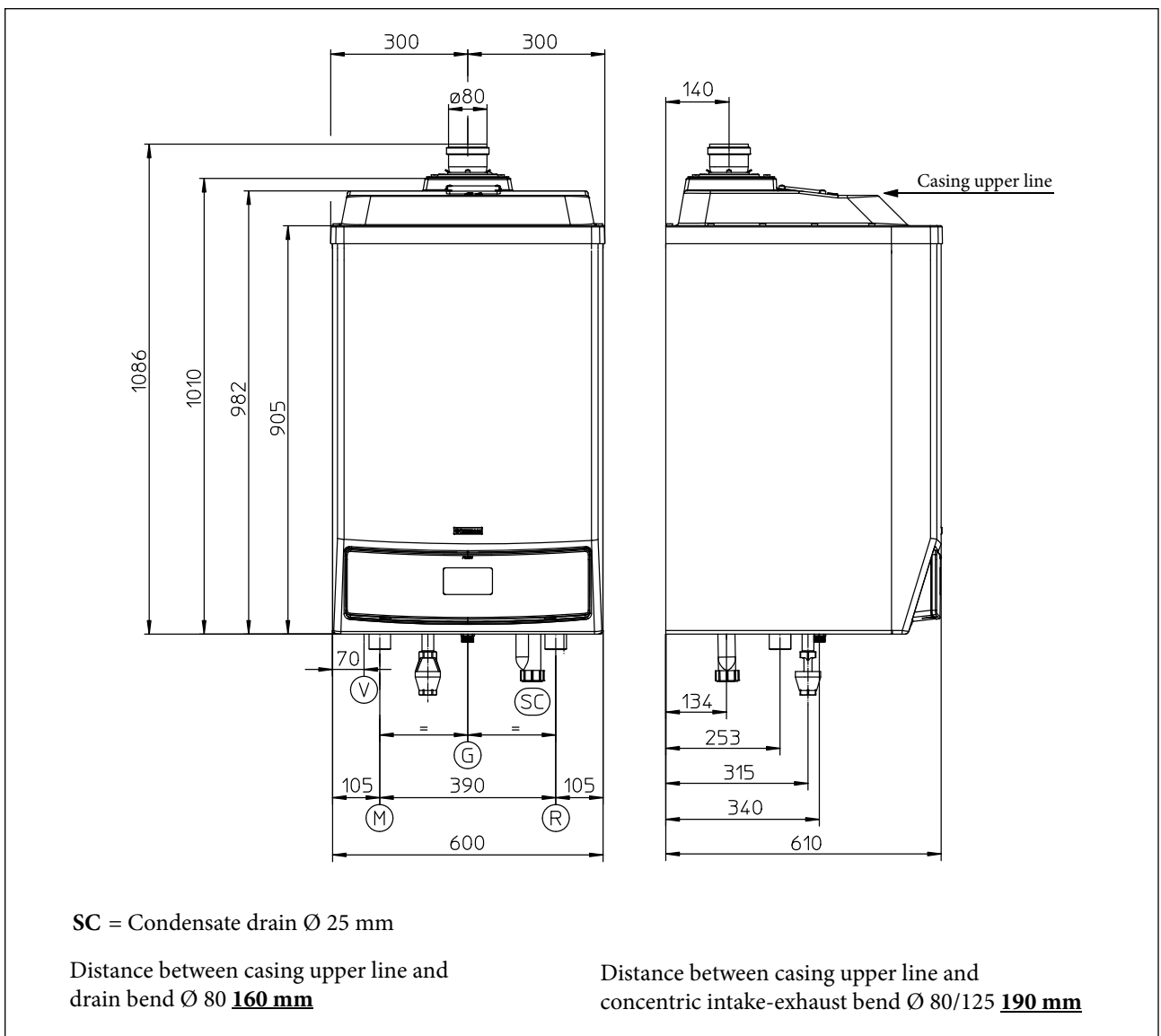

Model	System flow M	System return R	Gas Supply G
VICTRIX 90	1" 1/2	1" 1/2	3/4"
VICTRIX 115	1" 1/2	1" 1/2	1"



7DIMENSIONS AND HYDRAULIC KIT CONNECTIONS (OPTIONAL) WITH INDIVIDUAL BOILER

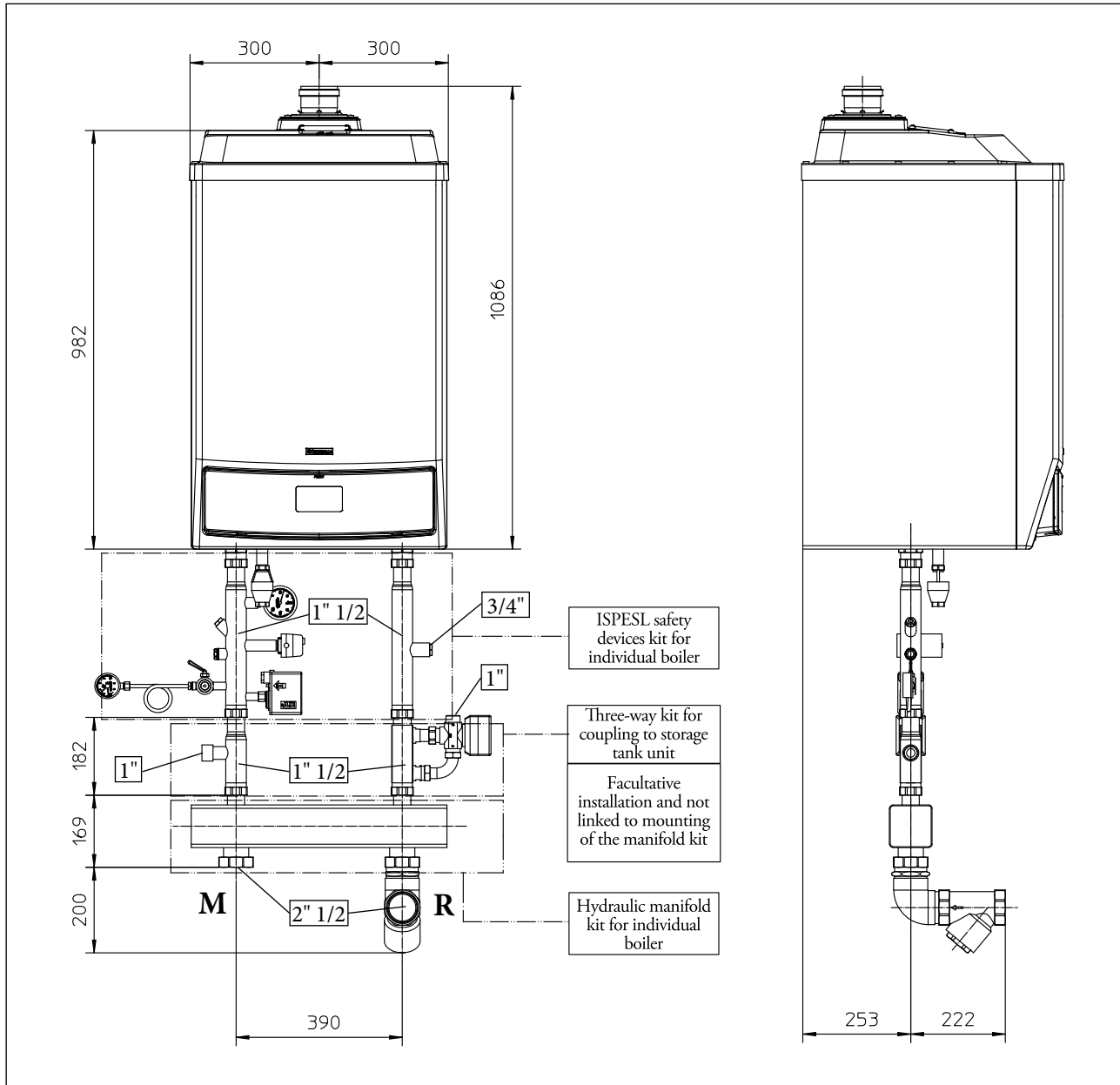

N.B.: In the case of installation outside, the ISPEL safety devices kit must be protected using the IPX4D protection box kit for ISPEL individual boiler safety devices, code 3.019175. Immergas S.p.a. declines all liability whenever the installer does not use the devices and Immergas ISPEL-approved original kits or uses them improperly. The sensitive elements of the automatic regulation and block circuit breaker switches and of the thermometer (not supplied as standard with the boiler) must be set-up as described in the installation instructions in compliance with the provisions of the "R" collection.

Regarding ISPEL design, when installing the Immergas safety kits, the following ISPEL approved devices are already present: Manometer-holder cock, manometer, thermometer, manual rearm thermostat and manual rearm pressure switch, (the boiler is already equipped as per standard with ISPEL approved 2 bar safety valve and draining funnel). The connection for the expansion vessel is set-up on the system return.

VICTRIX 90 - 115

8 DIMENSIONS AND HYDRAULIC KIT CONNECTIONS (OPTIONAL) WITH BOILERS VICTRIX 90 IN CASCADE (UP TO A MAXIMUM OF THREE APPLIANCES)

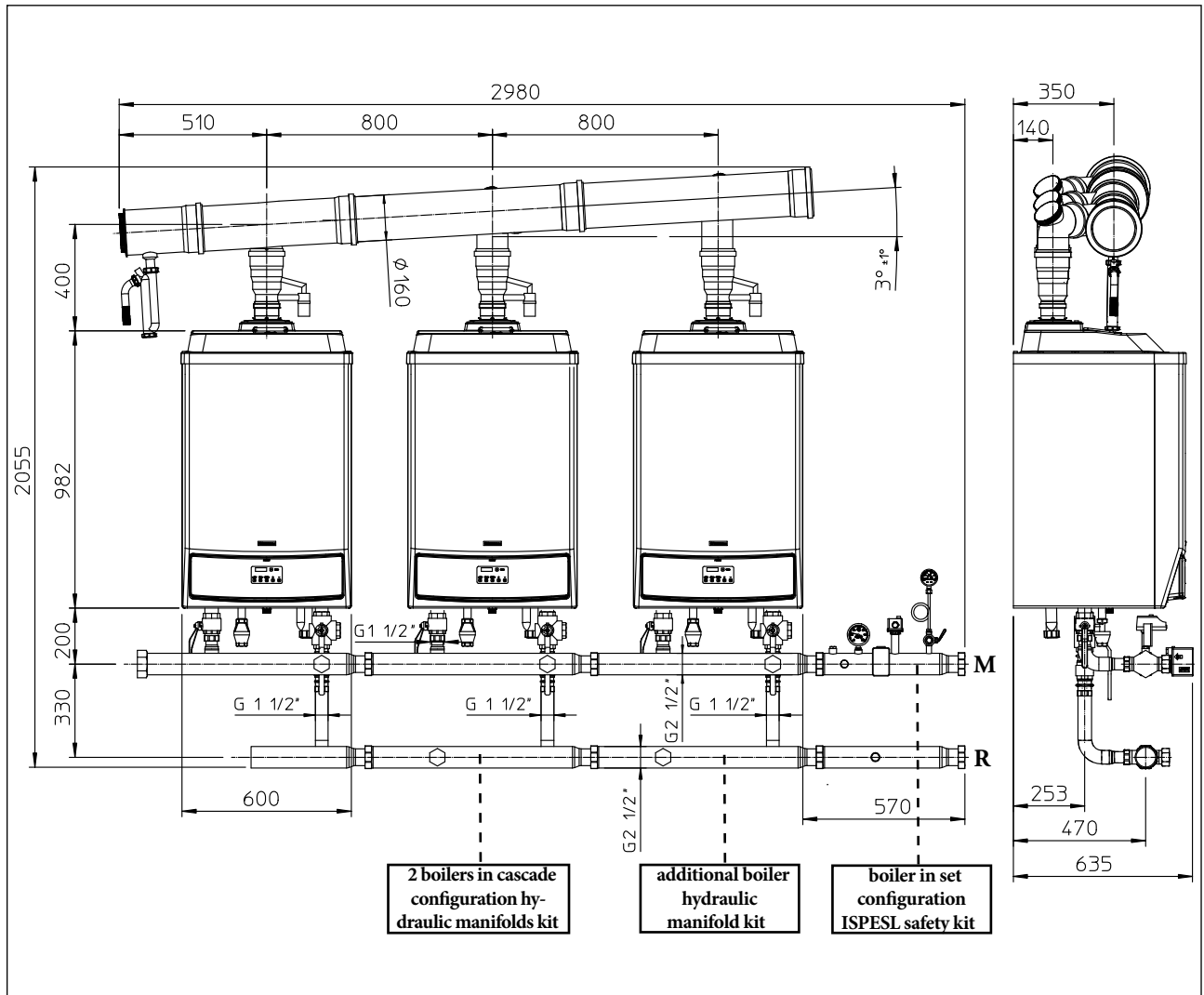

N.B.: In the case of installation outside, the ISPEL safety devices kit must be protected using the IPX4D protection box kit for ISPEL set configuration boiler safety devices, code 3.019185.

Immergas S.p.a. declines all liability whenever the installer does not use the devices and Immergas ISPEL-approved original kits or uses them improperly.

The sensitive elements of the automatic regulation and block circuit breaker switches and of the thermometer (not supplied as standard with the boiler) must be set-up as described in the installation instructions in compliance with the provisions of the "R" collection.

Regarding ISPEL design, when installing the Immergas safety kits, the following ISPEL approved devices are already present:

Manometer-holder cock, manometer, thermometer, manual

rearm thermostat and manual rearm pressure switch, (the boiler is already equipped as per standard with ISPEL approved 2 bar safety valve and draining funnel).

The connection for the expansion vessel is set-up on the system return.

The modular boilers, i.e. installed in cascade (battery) with an Immergas original hydraulic manifold kit, must be considered a unique appliance, which assumes the serial number (factory number) of the boiler nearest to the ISPEL safety devices. It is therefore possible to flank up to 3 modules, with a unique ISPEL safety kit.

The hydraulic manifolds (optional) are equipped with non-return valve positioned on the return pipe and with system interception cocks positioned on the flow and return pipes of every boiler (2-way on flow and 3-way on return).



9 DIMENSIONS AND HYDRAULIC KIT CONNECTIONS (OPTIONAL) WITH BOILERS VICTRIX 115 IN CASCADE (UP TO A MAXIMUM OF THREE APPLIANCES)

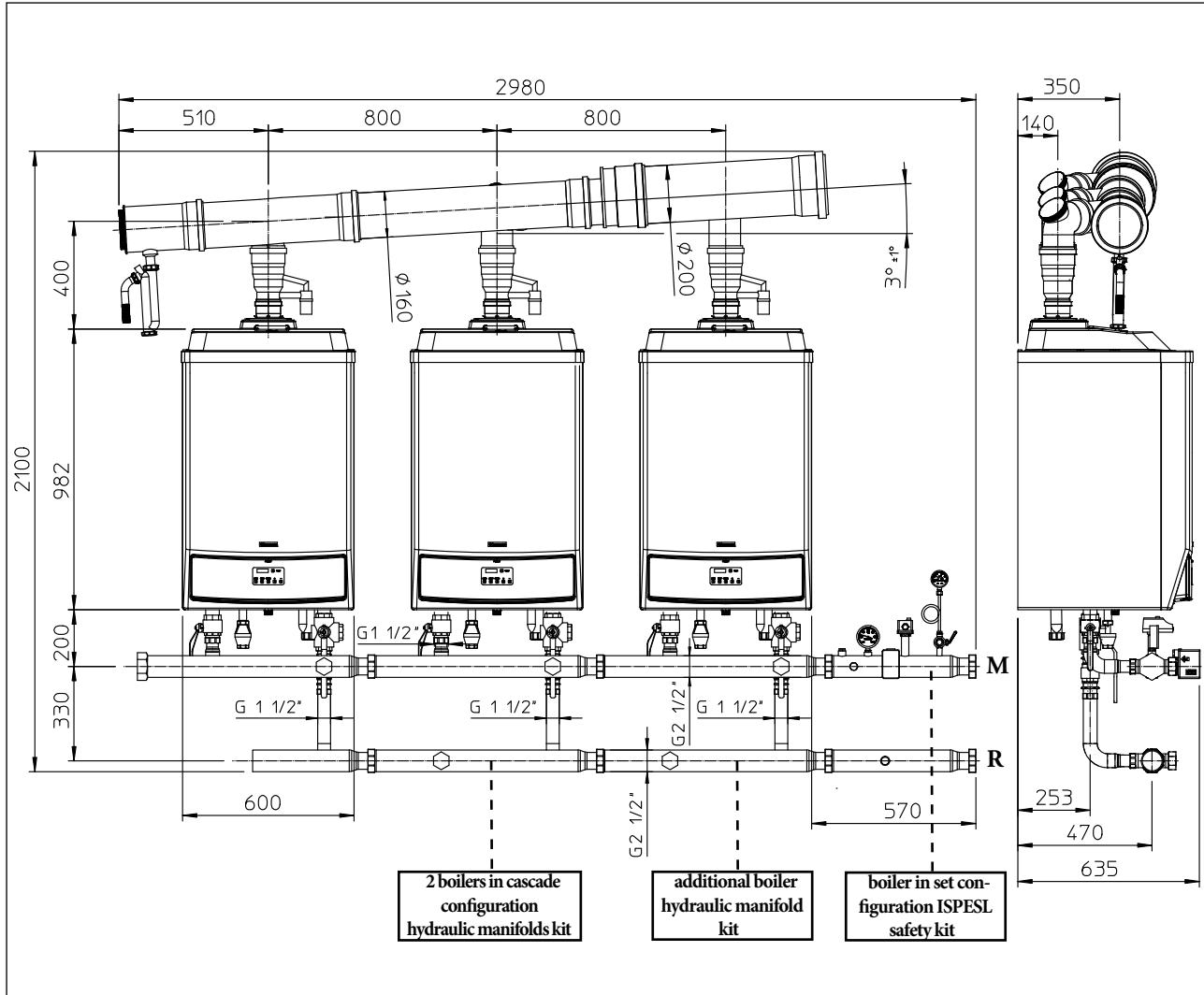

N.B.: In the case of installation outside, the ISPEL safety devices kit must be protected using the IPX4D protection box kit for ISPEL set configuration boiler safety devices, code 3.019185.

Immergas S.p.a. declines all liability whenever the installer does not use the devices and Immergas ISPEL-approved original kits or uses them improperly.

The sensitive elements of the automatic regulation and block circuit breaker switches and of the thermometer (not supplied as standard with the boiler) must be set-up as described in the installation instructions in compliance with the provisions of the "R" collection.

Regarding ISPEL design, when installing the Immergas safety kits, the following ISPEL approved devices are already present:

Manometer-holder cock, manometer, thermometer, manual

rearm thermostat and manual rearm pressure switch, (the boiler is already equipped as per standard with ISPEL approved 2 bar safety valve and draining funnel).

The connection for the expansion vessel is set-up on the system return.

The modular boilers, i.e. installed in cascade (battery) with an Immergas original hydraulic manifold kit, must be considered a unique appliance, which assumes the serial number (factory number) of the boiler nearest to the ISPEL safety devices. It is therefore possible to flank up to 3 modules, with a unique ISPEL safety kit.

The hydraulic manifolds (optional) are equipped with non-return valve positioned on the return pipe and with system interception cocks positioned on the flow and return pipes of every boiler (2-way on flow and 3-way on return).

VICTRIX 90 - 115

10 PUMP HEAD FLOW RATE GRAPHICS

The VICTRIX 90 boilers are supplied with a built-in circulation pump with 3-position electric speed control. The pump is the single-phase type (230 V - 50 Hz) and is already equipped with condenser. To ensure optimal boiler operation, in the case of new systems (single pipe and module) it is recommended to use the pump at maximum speed.

10.1 VICTRIX 90 PUMP

GRUNDFOS UPS 25-105

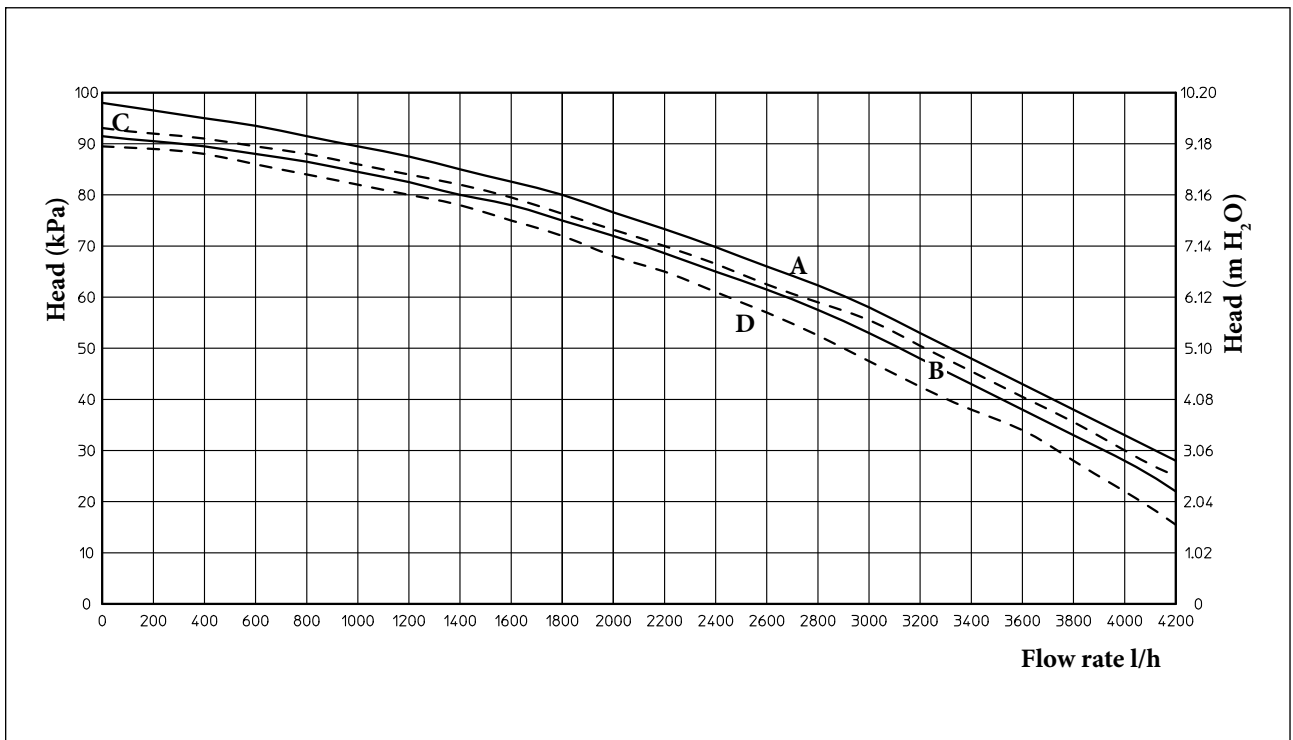

- A** = Head available to the system on the individual boiler maximum speed
- B** = Head available to the system on the individual boiler second speed
- C** = Head available to the system on maximum speed with the non-return valve for boilers in cascade (set)
- D** = Head available to the system on second speed with the non-return valve for boilers in cascade (set)



11

PUMP HEAD FLOW RATE GRAPHICS

The VICTRIX 115 boilers are supplied with a built-in circulation pump with 3-position electric speed control. The pump is the single-phase type (230 V - 50 Hz) and is already equipped with condenser. To ensure optimal boiler

operation, in the case of new systems (single pipe and module) it is recommended to use the pump at maximum speed.

11.1

VICTRIX 115 PUMP

GRUNDFOS UPS 25-105

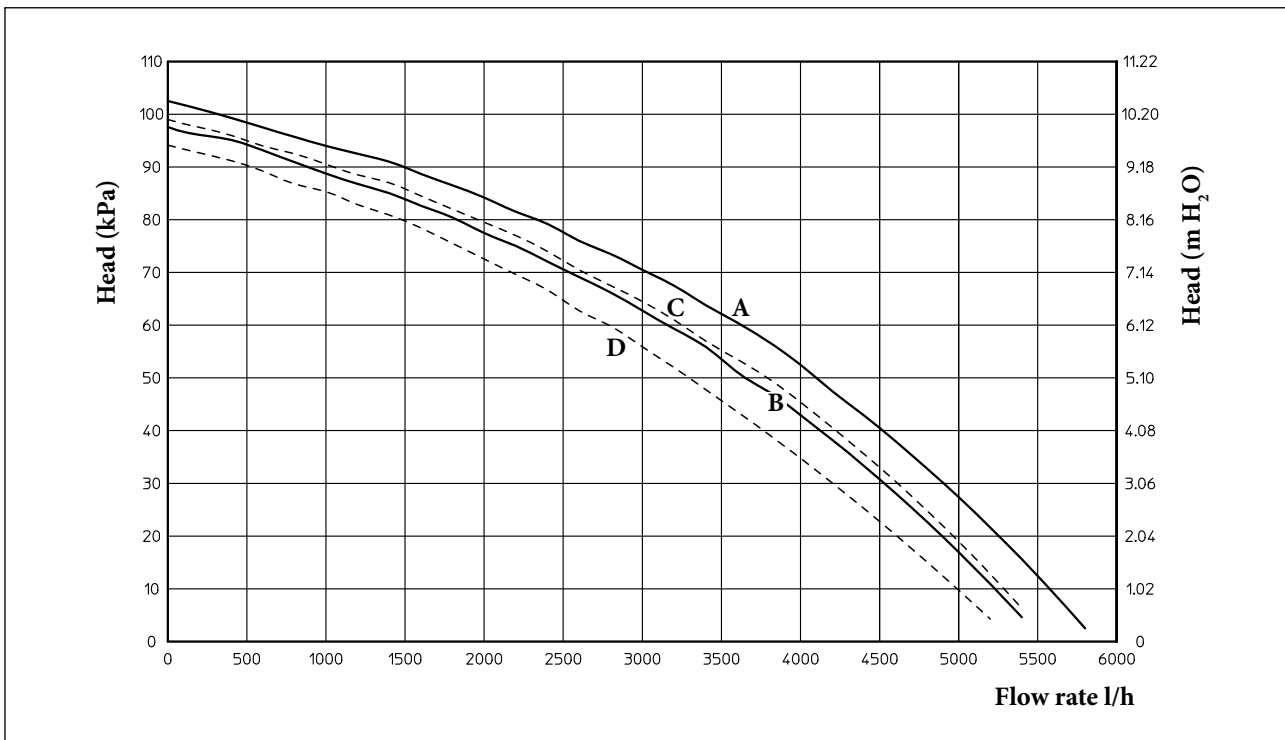

- A = Head available to the system on the individual boiler maximum speed
- B = Head available to the system on the individual boiler second speed
- C = Head available to the system on maximum speed with the non-return valve for boilers in cascade (set)
- D = Head available to the system on second speed with the non-return valve for boilers in cascade (set)

VICTRIX 90 - 115

12

HEAT ADJUSTMENT SYSTEMS (OPTIONAL)

System heating.

Individual modular boilers or installed in cascade configuration, require a suitable heat regulation system able to communicate simply with the boiler, in order to satisfy the most varied system requirements.

For this reason it is possible to couple a series of accessories to VICTRIX 90 and 115 boilers with the purpose of optimising the climatic regulation of the heating system.

In synthesis VICTRIX 90 and 115 can be installed with two types of plant:

- **In cascade** (with the system divided into one or more zones), use the cascade regulator coupling the zone manager or the modulating room thermostat for the heat adjustment of the individual zones.
- **Individually** (with the system divided into zones), use the cascade regulator coupling the zone manager or the modulating room thermostat for the heat adjustment of the individual zones. In the case of individual zone or three-way valve kit coupling, an ON-OFF room chrono-thermostat must be used.

Production of Domestic Hot Water.

Both in the case of single installation or in sets, the set-ups for coupling with a separate storage tank unit are supplied with relevant kits, available in the 200, 300, 500, 1000, 1500 and 2000 litre versions. The Storage Tank units are equipped with double coil for heat exchange. They are designed for coupling to Immergas solar solutions for the production of hot water in large houses or condominiums, as well as sport structures and hotels.

With VICTRIX 90 and 115 it is possible to select two different coupling systems of the separate storage tank unit:

- **Three-way valve kit for coupling the separate storage tank unit (in the case of installation of individual boiler).** The connection to the separate storage tank takes place simply by positioning the 3-way valve and replacing the NTC probe, present as per standard on the storage tank, with the probe contained in the 3-way valve kit. In this case, the heating system and the DHW system are managed by the boiler electronics; the cascade and zone regulator kit does not have to be envisioned.
- **Cascade and zone regulator kit.** Here, the storage tank unit is managed as zone via an external pump. This is possible with individual configuration and also with boilers in set configuration. In this case, the storage tank unit is controlled by the separate storage tank probe, which replaces the NTC temperature probe, present as per standard on the unit itself.



13

CASCADE AND ZONE REGULATOR (CODE 3.015244)



The cascade and zones regulator allows to manage, control and program the functioning sequence of the connected boilers. It can be set and programmed via parameters that allow to guarantee ideal temperature conditions at all times of the day and night for each individual day of the week, both for the CH system and the DHW system (VICTRIX 90 - 115 coupled to a storage tank unit). The cascade regulator can be inserted inside the electric control board present in the cabinet or recessed inside a support that allows fixing to the wall.

N.B.: with installation of the cascade regulator it is recommended to install the external probe to be connected to just one module.

13.1

FEATURES

The electrical connection is made with 2 wires powered at 230V (diameter 1.5 mm²).

The connection to the boiler takes place with 2 BUS data cables with maximum length of 50 metres and allows to:

- manage a maximum of three zones (of which 2 may be mixed) and a zone for the separate DHW storage tank. Given that a maximum of 5 cascade regulators can be coupled (of which one, the so-called Master, will be connected to the boiler P.C.B.), a total of up to 15 zone systems can be served (of which 10 eventually mixed) and 5 separate storage tank units;
- set two room temperature values, one for day (comfort temperature) and one for night (reduced temperature);
- manage the temperature of the DHW (with a storage tank unit managed as zone with a pump);
- select the functioning mode for CH and DHW for each individual hydraulic circuit:
 - comfort temperature functioning,
 - reduced temperature functioning,
 - adjustable anti-freeze temperature functioning;
- manage the boiler flow temperature depending on the external temperature with setting of the climatic curve;
- obtain information regarding the system:
 - system temperature,
 - functioning mode,
 - counter data,
 - timer program,
 - pumps functioning state,
 - functioning and values of the variable inputs;
- setting the functioning parameters:
 - functioning times,
 - system mode,
 - DHW,
 - direct circuit, mixed 1, mixed 2,
 - date and time;
- show on the display, via self-diagnosis system, any functioning anomalies with error codes;
- show the date, time, day of the week and the boiler temperature on the display,
- the regulator has a specific section for setting the solar system parameters.

VICTRIX 90 - 115

14

ZONE MANAGER (CODE 3.015264)



In addition to the functions described for the cascade heat adjuster, the cascade regulator allows to control all the important information regarding operation of the appliance and the heating system with the opportunity of easily intervening on the previously set parameters without having to go to the place where the cascade regulator is installed. The climate chrono-thermostat incorporated into the remote panel enables the system flow temperature to be adjusted to the actual needs of the room being heated, in order to obtain the desired room temperature with extreme precision and therefore with evident saving in running costs. Also allows to display the room temperature and the effective external temperature. The zone manager is powered directly by the cascade regulator via 2 BUS data cables.

14.1

FEATURES

The connection to the cascade regulator takes place with 2 BUS data cables with maximum length of 50 metres and allows to:

- manage a zone to maximum;
- set two room temperature values, one for day (comfort temperature) and one for night (reduced temperature);
- manage the temperature of the DHW (with a storage tank unit managed as zone);
- select the functioning mode for CH and DHW for each individual hydraulic circuit:
 - comfort temperature functioning,
 - reduced temperature functioning,
 - adjustable anti-freeze temperature functioning;
- manage the boiler flow temperature depending on the external temperature and the room temperature with setting of the climatic curve;
- obtain information regarding the system:
 - system temperature,
 - functioning mode,
 - counter data,
- timer program,
- pumps functioning state,
- functioning and values of the variable inputs;
- setting the functioning parameters:
 - functioning times,
 - system mode,
 - DHW,
 - direct circuit, mixed 1, mixed 2,
 - date and time;
- show on the display, via self-diagnosis system, any functioning anomalies with error codes;
- show the date, time, day of the week and the boiler temperature on the display.



15

MODULATING ROOM THERMOSTAT (CODE 3.015245)



The modulating room thermostats (not traditional On/Off) functions only when coupled with the cascade regulator and allows regulation of the room temperature of one of the zones into which the plant is divided (both in individual and cascade installation).

The zone room temperature regulation curve can be regulated by acting directly on the cascade regulator.

The modulating room thermostat is powered directly by the cascade regulator via 2 BUS data cables.

15.1

FEATURES

The connection to the cascade regulator takes place with 2 BUS data cables with maximum length of 50 metres and allows to:

- manage a zone to maximum;
- vary the room temperature of the zone;
- select the functioning mode for heating the zone:
 - fixed comfort temperature functioning,
 - fixed reduced temperature functioning,
 - functioning with timer program.

16

EXTERNAL PROBE (CODE 3.015266)



The external probe allows to decrease or increase the max. flow temperature to the system when the external temperature increases or decreases, in order to adjust the heat supplied to the system according to the change in external temperature.

The probe is connected via two wires directly to the boiler terminal board. Once connected, it always acts without heat regulation kit.

In the case of boilers installed in set configuration (several boilers), the external probe must be connected to just one boiler.

VICTRIX 90 - 115

17

SYSTEM EXAMPLES OF INDIVIDUAL 90-115 VICTRIX BOILERS

KEY:

- | | | | |
|------|---|------|--|
| 1 - | VICTRIX 90-115 boiler | 15 - | Storage tank unit feeding pump |
| 2 - | Cascade and zone regulator | 16 - | Zone 1 safety thermostat (CMI-1) |
| 3 - | Zone manager | 17 - | Zone 2 safety thermostat (CMI-2) |
| 4 - | Modulating room thermostat | 19 - | Fuel shut-off valve bulb |
| 5 - | External probe | 20 - | ISPEL type-approved manometer-holder cock |
| 6 - | Zone 1 temperature probe (CMI-1) | 21 - | ISPEL type-approved thermometer |
| 7 - | Zone 2 temperature probe (CMI-2) | 22 - | ISPEL type-approved manual rearm thermostat |
| 8 - | Common flow probe | 23 - | ISPEL type-approved manual rearm pressure switch |
| 9 - | Storage tank unit temperature probe | 24 - | Attachment for expansion vessel |
| 10 - | Zone 1 mixing valve (CMI-1) | 25 - | Expansion vessel |
| 11 - | Zone 2 mixing valve (CMI-2) | 26 - | Manifold/mixer |
| 12 - | Zone 1 central heating circuit pump (CMI-1) | 27 - | External storage tank unit |
| 13 - | Zone 2 central heating circuit pump (CMI-2) | 28 - | Fuel shut-off valve |
| 14 - | Zone 3 direct circuit pump (CD) | 29 - | Non return valve |
| | | 30 - | Slurry collection system filter |
| | | 31 - | Manometer pocket |
| | | 32 - | Damper coil |
| | | 33 - | ISPEL type-approved manometer |

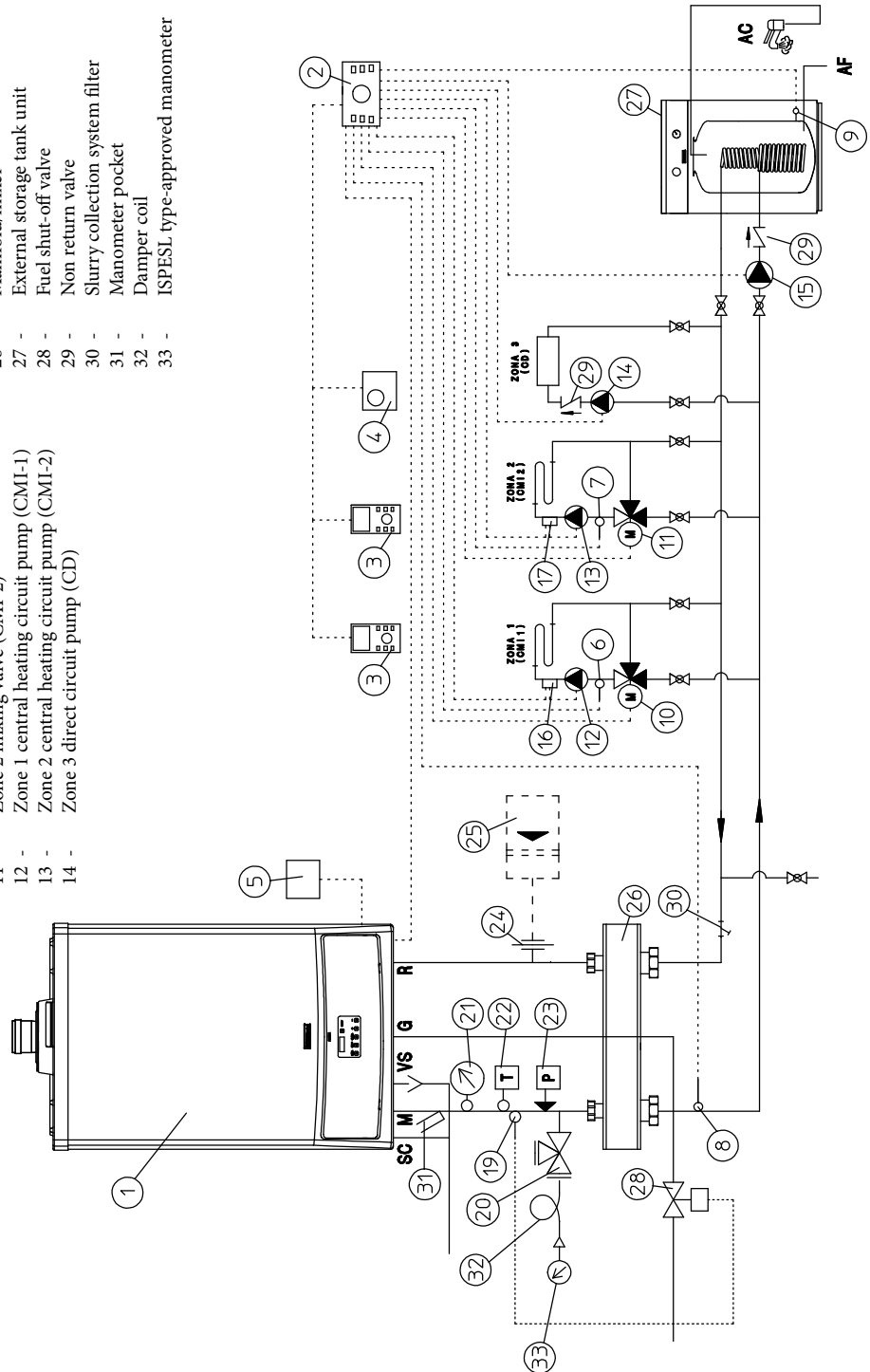

18 SYSTEM EXAMPLES OF 90-115 VICTRIX BOILERS IN CASCADE CONFIGURATION

KEY:

- | | | | |
|------|---|------|---|
| 1 - | VICTRIX 90-115 boiler | 15 - | Storage tank unit feeding pump |
| 2 - | Cascade and zone regulator | 16 - | Zone 1 safety thermostat (CMI-1) |
| 3 - | Zone manager | 17 - | Zone 2 safety thermostat (CMI-2) |
| 4 - | Modulating room thermostat | 19 - | Fuel shut-off valve bulb |
| 5 - | External probe | 20 - | ISPESL type-approved manometer-holder cock |
| 6 - | Zone 1 temperature probe (CMI-1) | 21 - | ISPESL type-approved thermometer |
| 7 - | Zone 2 temperature probe (CMI-2) | 22 - | ISPESL type-approved manual reararm pressure switch |
| 8 - | Common flow probe | 23 - | ISPESL type-approved manual reararm thermostat |
| 9 - | Storage tank unit temperature probe | 24 - | Attachment for expansion vessel |
| 10 - | Zone 1 mixing valve (CMI-1) | 25 - | Expansion vessel |
| 11 - | Zone 2 mixing valve (CMI-2) | 26 - | Manifold/mixer |
| 12 - | Zone 1 central heating circuit pump (CMI-1) | 27 - | External storage tank unit |
| 13 - | Zone 2 central heating circuit pump (CMI-2) | 28 - | Fuel shut-off valve |
| 14 - | Zone 3 direct circuit pump (CD) | 29 - | Non return valve |
| | | 30 - | Slurry collection system filter |
| | | 31 - | Manometer pocket |
| | | 32 - | Flue circuit flue adjusting device |
| | | 33 - | Stub pipe drain trap |
| | | 34 - | System shut-off valve |
| | | 35 - | Damper coil |
| | | 36 - | ISPESL type-approved manometer |

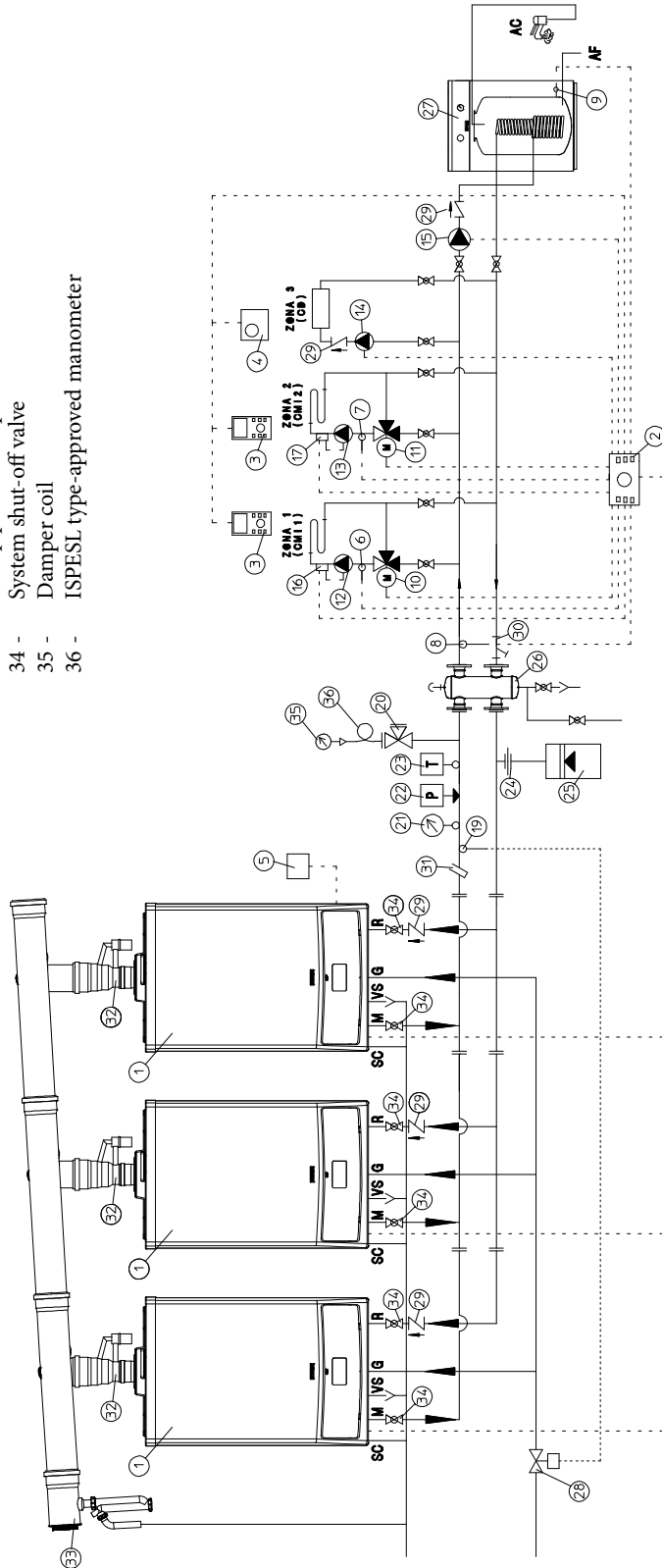

VICTRIX 90 - 115

19 WIRING DIAGRAM

OPTIONAL ELECTRIC CONNECTIONS.
 The connection of clamps M and O of the Bus are used to for the connection of the cascade and zone regulator.
 The room thermostat (S20) is connected to clamps F and E eliminating jumper X40.

The external probe (B4) is connected to clamps G and J.
 The DHW probe (B2) is connected to clamps R and H.
 The 3-way valve (M30) is connected to clamps T, S and K.
 The summer switch (S16) is connected to clamps V and U.

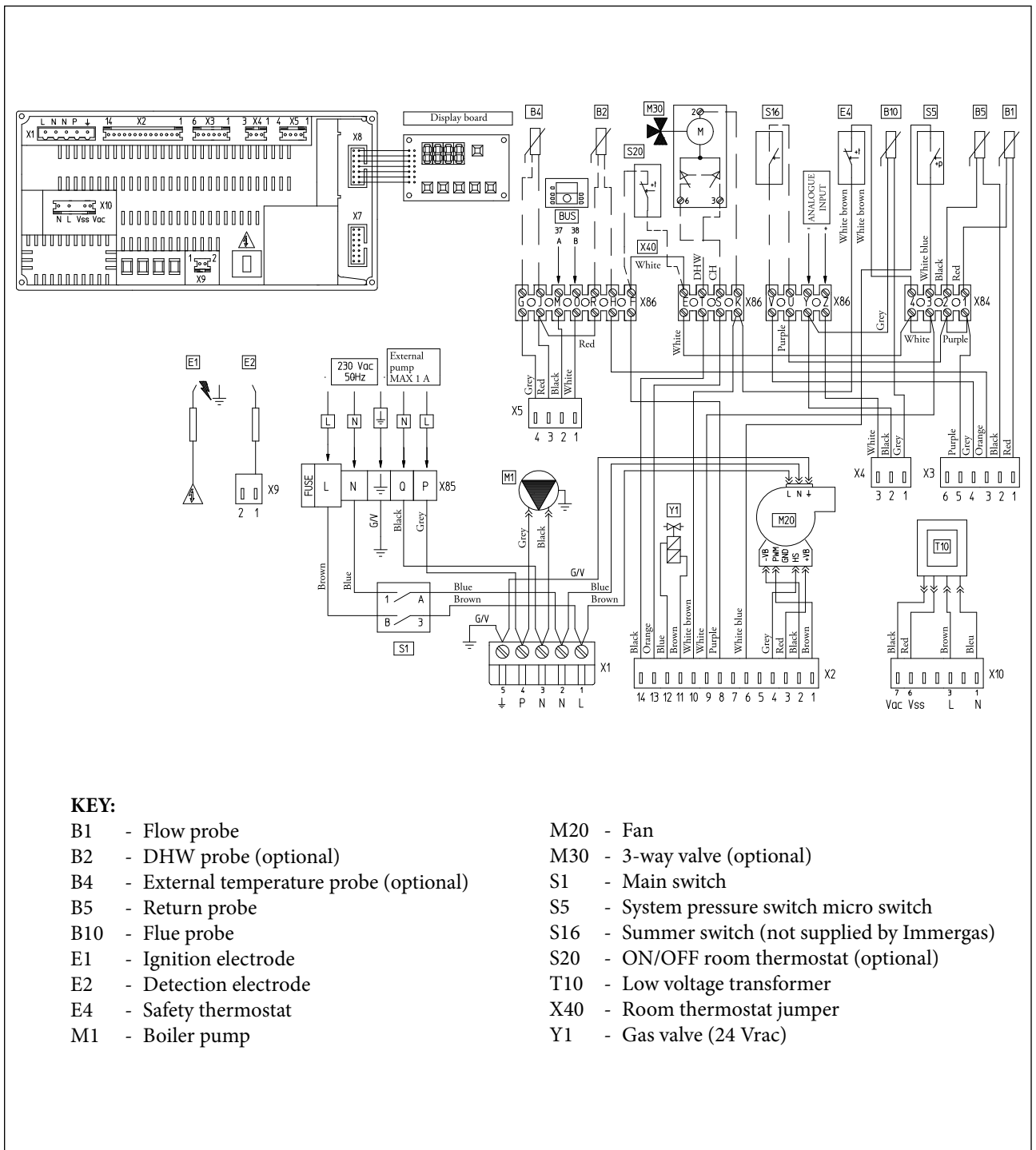

KEY:

- | | |
|--|--|
| B1 - Flow probe | M20 - Fan |
| B2 - DHW probe (optional) | M30 - 3-way valve (optional) |
| B4 - External temperature probe (optional) | S1 - Main switch |
| B5 - Return probe | S5 - System pressure switch micro switch |
| B10 - Flue probe | S16 - Summer switch (not supplied by Immergas) |
| E1 - Ignition electrode | S20 - ON/OFF room thermostat (optional) |
| E2 - Detection electrode | T10 - Low voltage transformer |
| E4 - Safety thermostat | X40 - Room thermostat jumper |
| M1 - Boiler pump | Y1 - Gas valve (24 Vrac) |



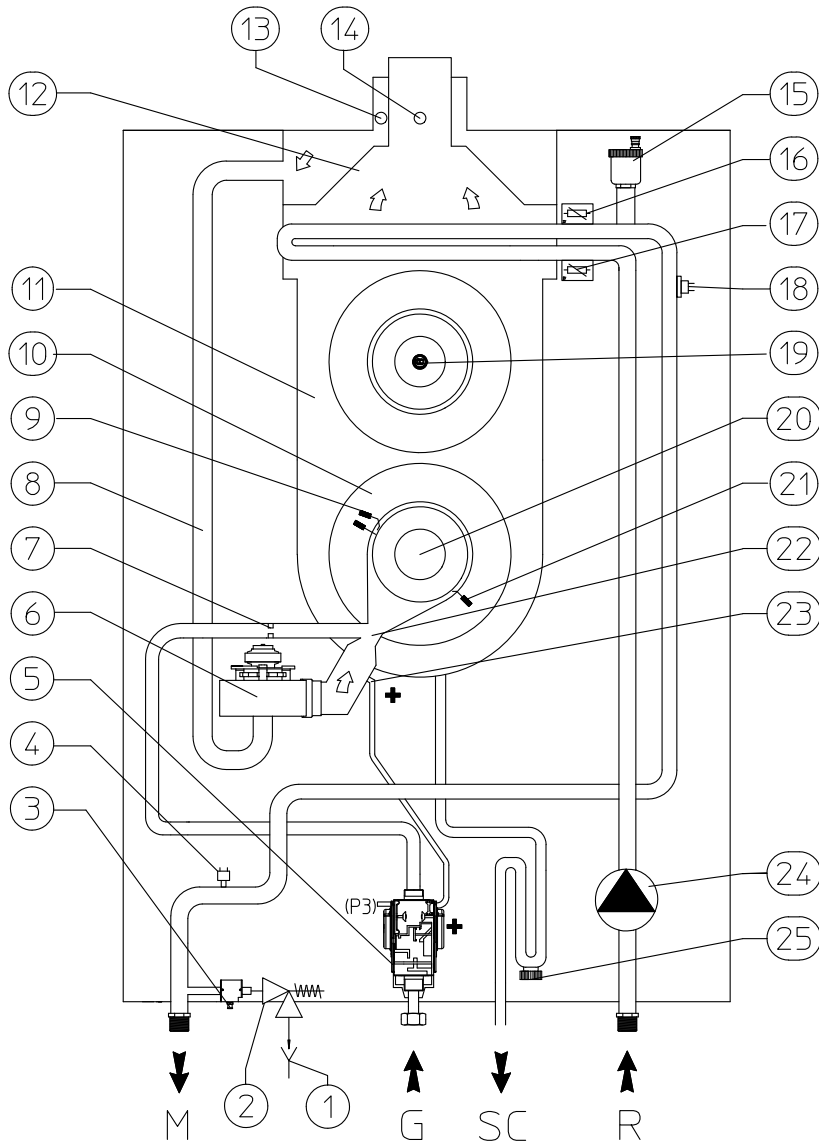

KEY:

- | | |
|--|-------------------------------------|
| 1 - Draining funnel on view | 14 - Flue sample point |
| 2 - ISPEL type-approved 4 bar safety valve | 15 - Automatic air vent valve |
| 3 - Boiler draining valve | 16 - System flow regulation probe |
| 4 - Absolute pressure switch | 17 - System return regulation probe |
| 5 - Gas valve | 18 - Over-heating safety thermostat |
| 6 - Air fan | 19 - Flue probe |
| 7 - Gas nozzle | 20 - Burner |
| 8 - Air intake pipe | 21 - Detection electrode |
| 9 - Ignition electrode | 22 - Air/gas Venturi manifold |
| 10 - Condensation module cover | 23 - Venturi positive sign (P1) |
| 11 - Condensation module | 24 - Boiler pump |
| 12 - Flue hood | 25 - Condensate trap siphon |
| 13 - Air sample point | |

VICTRIX 90 - 115

"GREEN RANGE" INTAKE/EXHAUST KIT MUST BE USED FOR VICTRIX 90-115

21

TYPE OF INSTALLATION

The VICTRIX 90-115 boilers are type-approved for installation outside or inside the heating control unit.

The "Victrix 90 -115" boilers leave the factory in "B₂₃" configuration (open chamber and fan assisted), to change the configuration of the boiler to type "C" (sealed chamber and fan assisted), disassemble the Ø 80 adapter, the bracket and the gasket present on the boiler cover, in this way the relevant Ø 80/125 kits can be used.

For correct installation of the boiler, the particular Immergas "Green" range air intake/fumes exhaust kits must be used as the materials, components and accessories are specific for this type of appliances.

The flue exhaust pipes are made in plastic, in a way to guarantee high resistance to corrosion and noteworthy rapidity and functionality in installation, also thanks to the push-fitting system and the sealing gaskets.

By varying the type of installation the classification of the boiler also varies:

Type C configuration, sealed chamber and fan assisted.

Installation takes place using the relevant Ø 80/125 concentric kits after having removed the Ø 80 adapter, the bracket and the gasket present on the boiler cover.

Air intake and flue exhaust takes place in this way directly to the outside of the building.

The following can be used as concentric intake/exhaust kit:
Ø 80/125 horizontal concentric kit **Code 3.015242;**

Ø 80/125 vertical concentric kit **Code 3.015243.**

Configuration type B₂₃ open chamber and forced draught.

Installation takes place using the Ø 80 adapter, as per standard, with the boiler to which the relevant Ø 80 flue exhaust kit is connected.

Air intake takes place directly from the environment in which the boiler is installed and flue exhaust into the flue or directly to the outside. It is therefore necessary to couple only one of the following flue exhaust kits:

Ø 80 horizontal terminal kit for wall flue exhaust

Code 3.015255;

Horizontal kit Ø 80 for exhaust in flue

Code 3.015254;

Ø 80 vertical terminal kit for direct discharge

Code 3.015256.

Installed individually, always in "B₂₃" configuration, VICTRIX 90-115 can also be coupled with the Ø 80 flexible ducting system for condensing boilers.

This system is particularly suitable for chimneys or flues (or technical slots) that are not perfectly straight, where a rigid ducting system could, in some cases, face difficulty during installation.

Installed in cascade configuration inside the heating control units or technical rooms, it is possible to use the relevant exhaust manifolds in the flue equipped with non-return devices (flue adjusting devices), in order to prevent the functioning boiler combustion products from interfering with the combustion circuit of other boilers that are off.



22

Ø 80/125 HORIZONTAL CONCENTRIC KIT (CODE 3.015242)

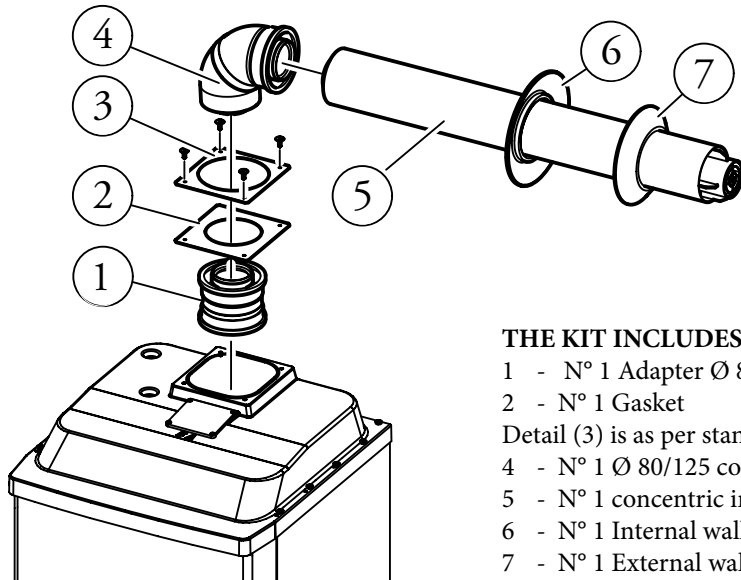

THE KIT INCLUDES:

- 1 - N° 1 Adapter Ø 80/125
- 2 - N° 1 Gasket
- Detail (3) is as per standard with the boiler
- 4 - N° 1 Ø 80/125 concentric bend at 87°
- 5 - N° 1 concentric intake-exhaust terminal Ø 80/125
- 6 - N° 1 Internal wall sealing plate
- 7 - N° 1 External wall sealing plate

Ø 80/125 HORIZONTAL KIT MAXIMUM LENGTH ACCEPTED

Horizontal metres

VICTRIX 90	10 + the first 90° bend
VICTRIX 115	7 + the first 90° bend

VICTRIX 90 - 115

23

Ø 80/125 VERTICAL CONCENTRIC KIT (CODE 3.015243)

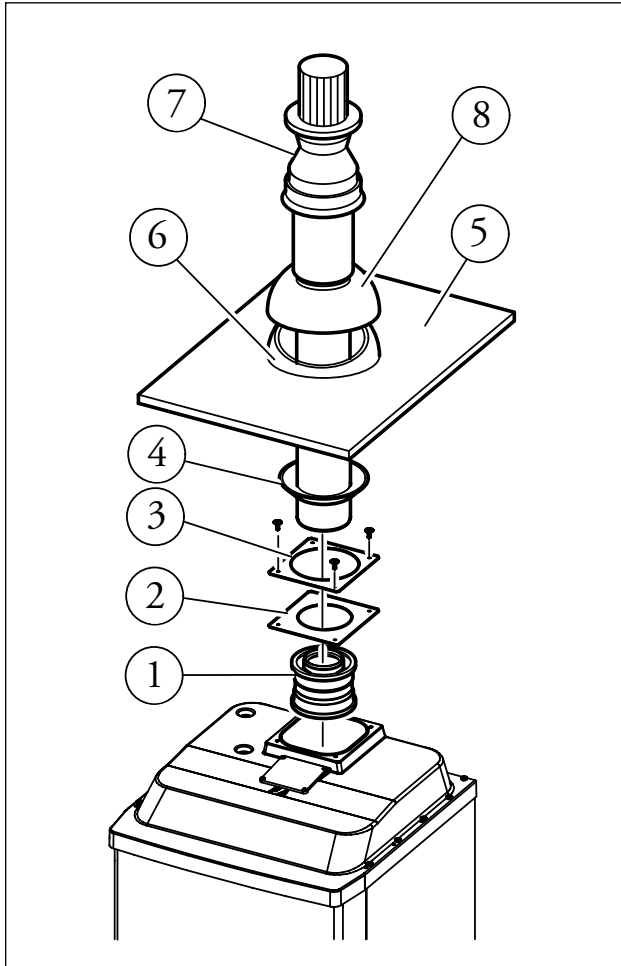

Ø 80/125 VERTICAL KIT MAXIMUM LENGTH ACCEPTED

Vertical metres

VICTRIX 90	12
VICTRIX 115	8

THE KIT INCLUDES:

- 1 - N° 1 Adapter Ø 80/125
- 2 - N° 1 Gasket
- Detail (3) is as per standard with the boiler
- 4 - N° 1 Wall sealing plate
- 5 - N° 1 - Aluminium tile
- 6 - N° 1 Fixed half-shell
- 7 - N° 1 concentric intake-exhaust terminal Ø 80/125
- 8 - N° 1 Mobile half-shell



24

Ø 80 VERTICAL KIT (CODE 3.015256)

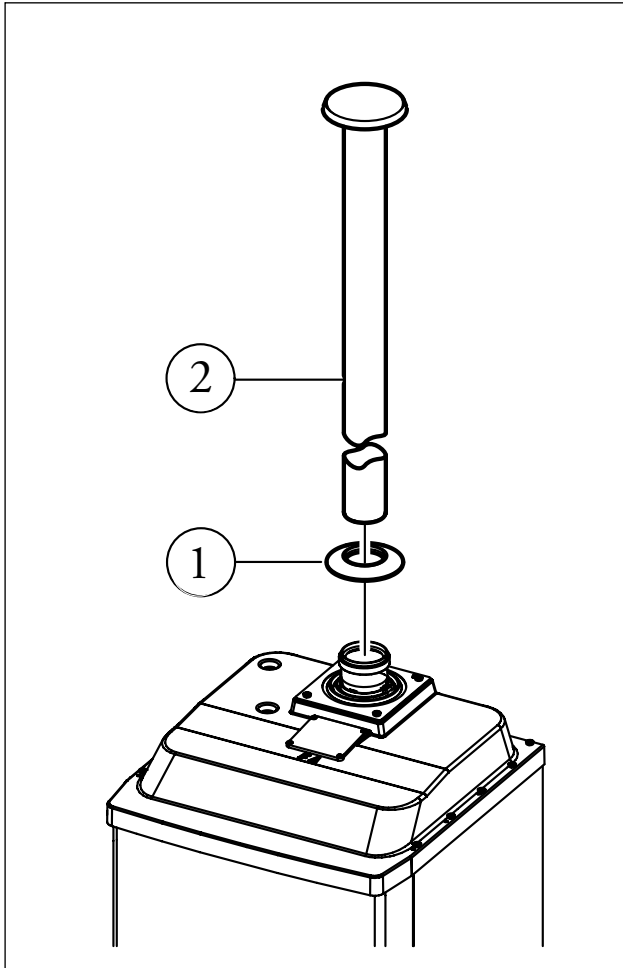

Ø 80 VERTICAL KIT MAXIMUM LENGTH ACCEPTED

Vertical metres

VICTRIX 90	17
VICTRIX 115	14,5

THE KIT INCLUDES:

- 1 - N° 1 Wall sealing plate
- 2 - N° 1 Ø 80 Drain terminal

VICTRIX 90 - 115

25 Ø 80 HORIZONTAL TERMINAL KIT FOR WALL FLUE EXHAUST (CODE 3.015255)

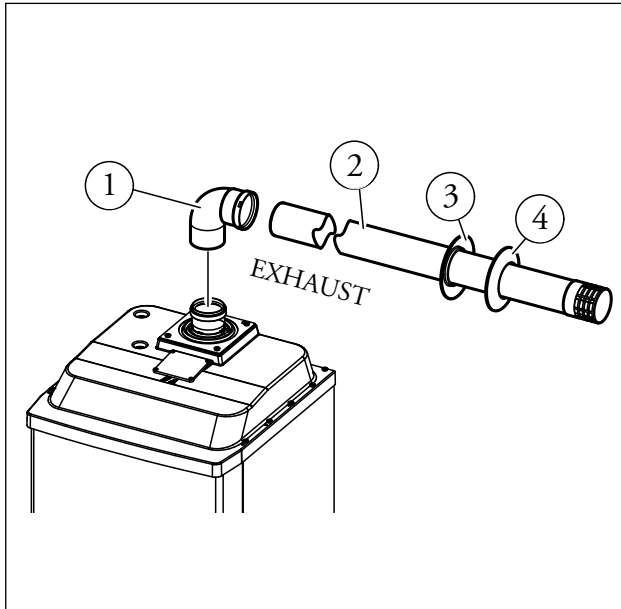

THE KIT INCLUDES:

- 1 - N° 1 Bend 90° Ø 80
- 2 - N° 1 Ø 80 Drain pipe
- 3 - N° 1 Internal wall sealing plate

Ø 80 HORIZONTAL KIT MAXIMUM LENGTH ACCEPTED

Horizontal metres

VICTRIX 90	17
VICTRIX 115	14,5

25.1 Ø 80 HORIZONTAL TERMINAL KIT FOR FLUE EXHAUST (CODE 3.015254)

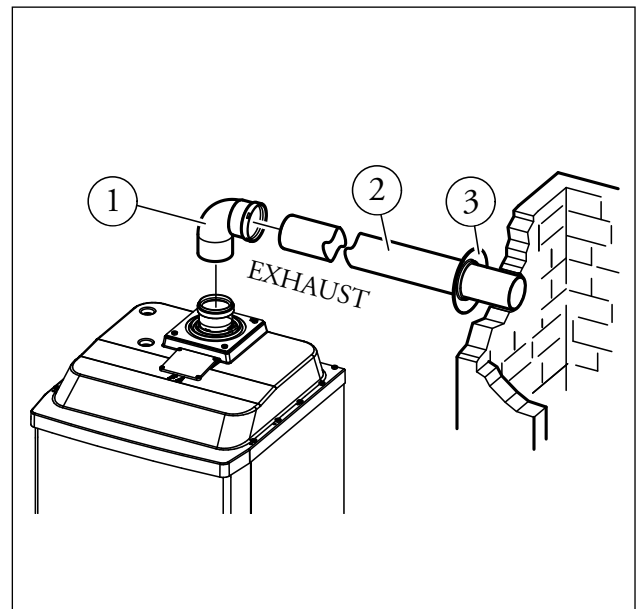

THE KIT INCLUDES:

- 1 - N° 1 Bend 90° Ø 80
- 2 - N° 1 Ø 80 Drain pipe
- 3 - N° 1 Internal wall sealing plate
- 4 - N° 1 External wall sealing plate



26

FLUE EXHAUST MANIFOLD KIT Ø 160 WITH TWO VICTRIX 90 BOILERS IN CASCADE CONFIGURATION (CODE 3.020476)

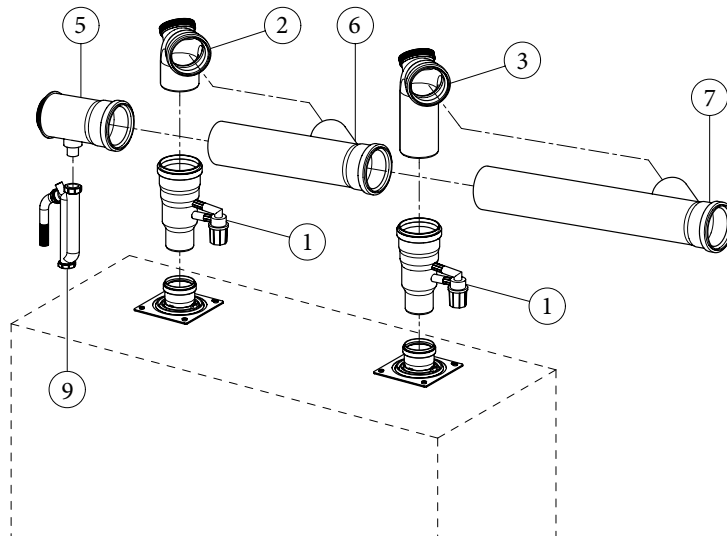

THE KIT INCLUDES:

- 1 - N° 1 Stub pipe with flue adjusting device
- 2 - N° 1 Short inspectionable bend
- 3 - N° 1 Long inspectionable bend
- 5 - N° 1 Condensate drain cap
- 6 - N° 1 Short pipe
- 7 - N° 1 Long pipe
- 9 - N° 1 Condensate drain trap

26.1

FLUE EXHAUST MANIFOLD KIT Ø 160 WITH ADDITIONAL VICTRIX 90 BOILER IN CASCADE CONFIGURATION (CODE 3.020701)

THE KIT INCLUDES:

- 1 - N° 1 Stub pipe with flue adjusting device
- 4 - N° 1 Inspectionable bend
- 7 - Pipes already present
- 8 - N° 1 Long pipe

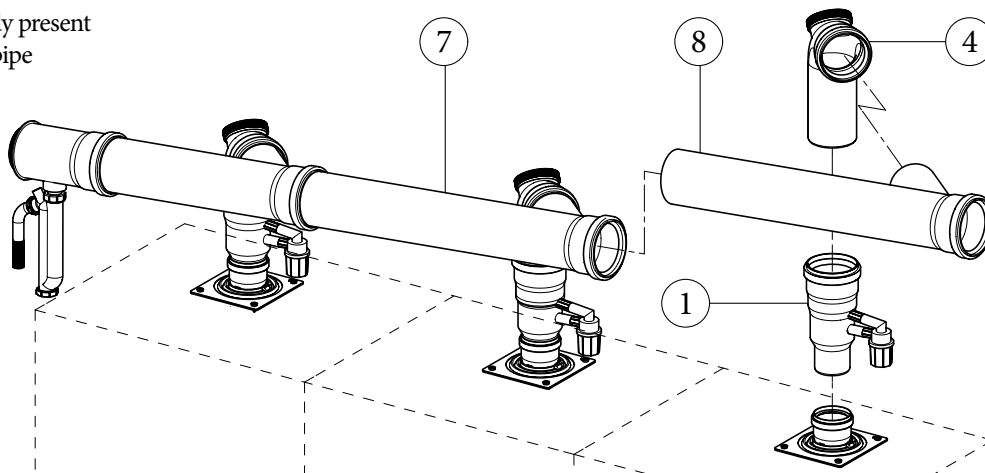

VICTRIX 90 - 115

27

FLUE EXHAUST MANIFOLD KIT Ø 160 WITH TWO VICTRIX 115 BOILERS IN CASCADE CONFIGURATION (CODE 3.020476)

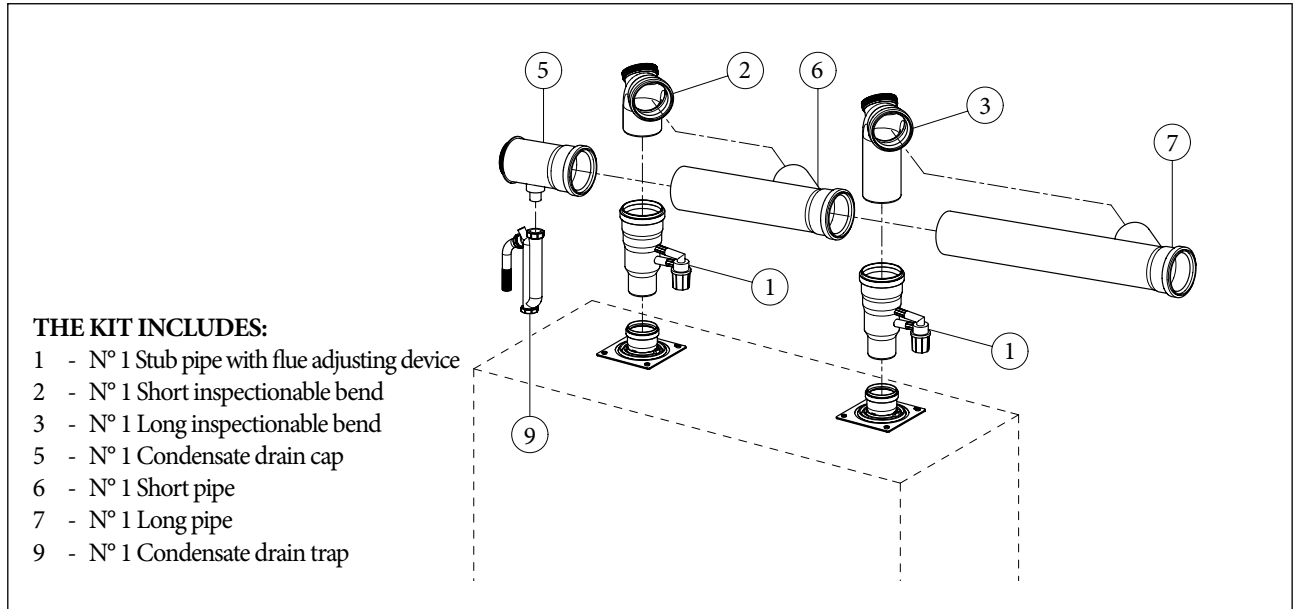

27.1

FLUE EXHAUST MANIFOLD KIT Ø 200 WITH ADDITIONAL VICTRIX 115 BOILER IN CASCADE CONFIGURATION (CODE 3.020954)

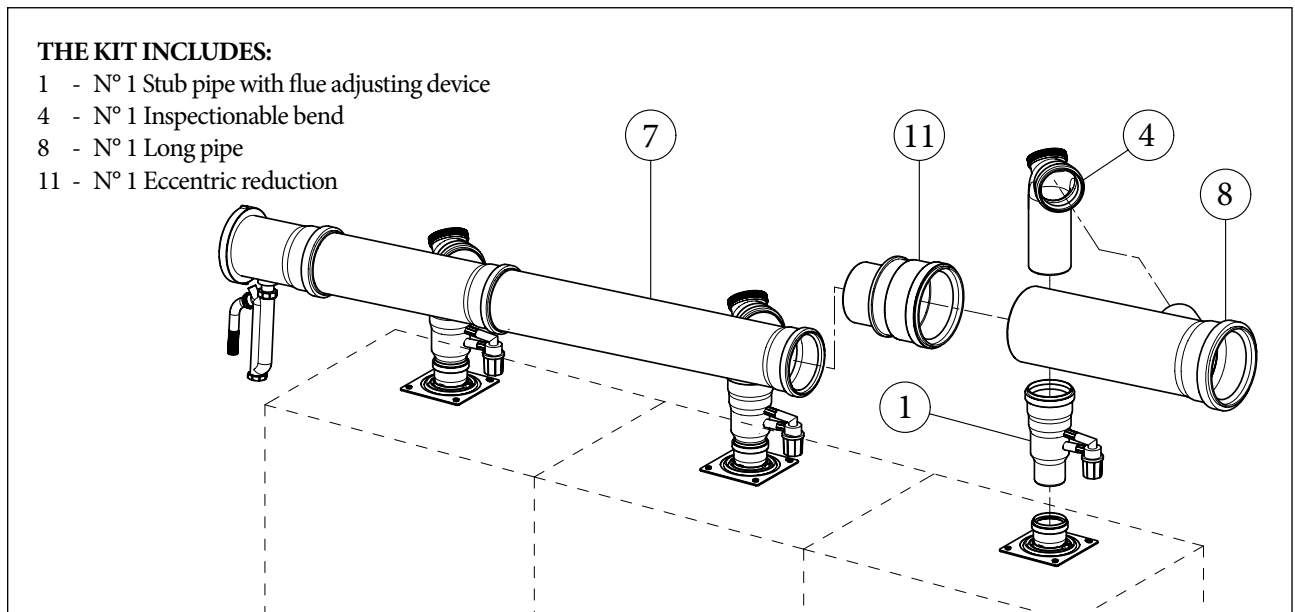

The Immergas Ø 80 mm system for flexible ducting of existing chimneys is made up from a series of components, identified as individual kits, which can be assembled depending on the specific installation requirements. This system is supplied in a configuration that envisions an ascending 87° input bend, then continuing vertically with the Ø 80 flexible tube and the exhaust terminal. The ducted tube is inspected at the mouth of the boiler, via the relevant hatch.

The kit is made up from a 12 m flexible tube. If the tube is too short it can be joined to other pieces via the relevant adapters. A centring spacer must however be inserted every now and again, which via extendable fins, allows the tube to stay in the centre of the flue.

The maximum length that can be run with this ducting system is equal to 17 m (approx.) for VICTRIX 90 and 14.5 m (approx.) for VICTRIX 115.

This length is obtained by considering:

- 1 Ø 80 mm 90° bend for connection to the boiler (exhaust);
- 1 m of Ø 80 tube for exhaust;
- two direction changes in the vertical tract;
- the Ø 80 mm support bend;
- the vertical terminal kit for ducting Ø 80/125.

It is important to highlight that:

- in all cases it is a system to which **a unique appliance can be coupled;**
- the system **can only be coupled with condensing appliances.**

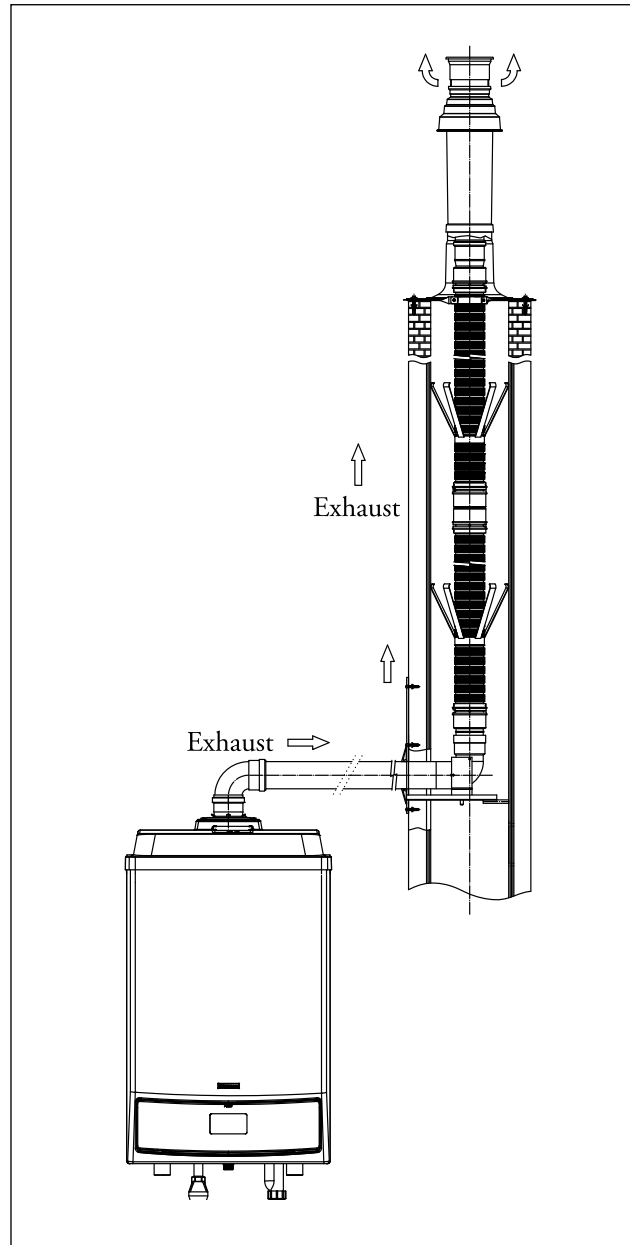

VICTRIX 90 - 115

29

VICTRIX 90 TECHNICAL DATA

Maximum nominal heat input		kW (kcal/h)	92.3 (79,417)
Maximum useful heat output		kW (kcal/h)	90.0 (77,400)
Minimum nominal heat input		kW (kcal/h)	23.0 (19,777)
Minimum nominal heat output		kW (kcal/h)	22.5 (19,350)
Efficiency at 100% Pn (80/60°C)		%	97.5
Efficiency at 30% of the load (80/60°C)		%	100.6
Efficiency at 100% Pn (50/30°C)		%	106.0
Efficiency at 30% of the load (50/30°C)		%	108.3
Efficiency at 100% Pn (40/30°C)		%	108.7
Efficiency at 30% of the load (40/30°C)		%	108.3
Central heating circuit			
System adjustable central heating temperature		°C	25-85
System max. working temperature		°C	90
System max. working pressure		bar	4.4
Total head available with 1000 l/h flow rate		kPa (m H ₂ O)	87.76 (8.95)
Gas supply			
METHANE fan speed (G20)	MIN - MAX	N° revs	1750 - 5900
LPG fan speed (G31)	MIN - MAX	N° revs	1750 - 5900
Gas flow rate at METHANE burner (G20)	MIN - MAX	m ³ /h	2.43 - 9.77
Gas flow rate at LPG burner (G31)	MIN - MAX	kg/h	1.79 - 7.17
Electric power supply		V/Hz	230 - 50
Power input		A	1.69
Installed electric power		W	370
Fan consumption		W	102.6
Pump consumption		W	238.7
Electric insulation rating	IP		X5D
Boiler water content		litres	10.1
Weight of empty boiler		kg	97.5
Useful efficiency at 100% output (Legislative Decree 192/05 and successive amendments)			>93+2.log Pn (Pn = 90.0 kW)



30

VICTRIX 115 TECHNICAL DATA

Maximum nominal heat input		kW (kcal/h)	112.8 (96,986)
Maximum useful heat output		kW (kcal/h)	111.0 (95,460)
Minimum nominal heat input		kW (kcal/h)	30.1 (25,896)
Minimum nominal heat output		kW (kcal/h)	29.5 (25,370)
Efficiency at 100% Pn (80/60°C)		%	98.4
Efficiency at 30% of the load (80/60°C)		%	100.3
Efficiency at 100% Pn (50/30°C)		%	106.8
Efficiency at 30% of the load (50/30°C)		%	106.4
Efficiency at 100% Pn (40/30°C)		%	108.7
Efficiency at 30% of the load (40/30°C)		%	108.8
Central heating circuit			
System adjustable central heating temperature		°C	25-85
System max. working temperature		°C	90
System max. working pressure		bar	4.4
Total head available with 1000 l/h flow rate		kPa (m H ₂ O)	92.18 (9.40)
Gas supply			
METHANE fan speed (G20)	MIN - MAX	N° revs	1750 - 5900
LPG fan speed (G31)	MIN - MAX	N° revs	1750 - 5700
Gas flow rate at METHANE burner (G20)	MIN - MAX	m ³ /h	3.19 - 11.94
Gas flow rate at LPG burner (G31)	MIN - MAX	kg/h	2.34 - 8.76
Electric power supply		V/Hz	230 - 50
Power input		A	1.8
Installed electric power		W	390
Fan consumption		W	117
Pump consumption		W	242.4
Electric insulation rating	IP		X5D
Boiler water content		litres	11.7
Weight of empty boiler		kg	10,5,5
Useful efficiency at 100% output (Legislative Decree 192/05 and successive amendments)			>93+2·log Pn (Pn = 111.0 kW)



VICTRIX 90 - 115

31	VICTRIX 90 COMBUSTION FEATURES
-----------	---------------------------------------

		Methane (G20)	LPG (G31)
Combustion efficiency 100% Pn (80/60°C)	%	98.2	98.2
Combustion efficiency P min (80/60°C)	%	98.3	98.3
Useful efficiency at 100% Pn (80/60°C)	%	97.5	97.5
Useful efficiency P min (80/60°C)	%	97.8	97.8
Useful efficiency at 100% Pn (50/30°C)	%	106.0	106.0
Useful efficiency P min (50/30°C)	%	108.2	108.2
Useful efficiency at 100% Pn (40/30°C)	%	108.7	108.7
Useful efficiency P min (40/30°C)	%	109.1	109.1
Chimney losses with burner on (100% Pn) (80/60°C)	%	1.80	1.80
Chimney losses with burner on (P min) (80/60°C)	%	1.70	1.70
Chimney losses with burner off	%	0.01	0.01
Casing losses with burner off	%	0.41	0.41
Casing losses with burner on (100% Pn) (80/60°C)	%	0.70	0.70
Casing losses with burner on (P min) (80/60°C)	%	0.50	0.50
Flue temperature Maximum Heat Input	°C	52	53
Flue temperature Minimum Heat Input	°C	49	49
Flue flow rate at Maximum Heat Input	kg/h	148	147
Flue flow rate at Minimum Heat Input	kg/h	37	38
CO ₂ at the Maximum Heat Input	%	9.3	10.7
CO ₂ at the Minimum Heat Input	%	9.1	10.2
CO at Maximum Heat Input	mg/kWh	192	226
CO at Minimum Heat Input	mg/kWh	11	13
NO _x at the Maximum Heat Input	mg/kWh	37	62
NO _x at the Minimum Heat Input	mg/kWh	14	32
Weighted CO	mg/kWh	20.0	-
Weighted NO _x	mg/kWh	23.3	-
NO _x class	-	5	5
Head available at fan (B ₂₃) (Min. - Max.)	Pa	2 - 170	
Head available at fan (C ₁₃) (Min. - Max.)	Pa	115 - 295	

Gas flow rates refer to the NHV at the temperature of 15° C and pressure of 1013 mbar.
 Flue temperature values refer to an air inlet temperature of 15°C and flow temperature of 50°C.



32	VICTRIX 115 COMBUSTION FEATURES
-----------	--







		Methane (G20)	LPG (G31)
Combustion efficiency 100% Pn (80/60°C)	%	98.2	98.2
Combustion efficiency P min (80/60°C)	%	98,5	98.5
Useful efficiency at 100% Pn (80/60°C)	%	98.4	98.4
Useful efficiency P min (80/60°C)	%	98.0	98.0
Useful efficiency at 100% Pn (50/30°C)	%	106.8	106.8
Useful efficiency P min (50/30°C)	%	108.2	108.2
Useful efficiency at 100% Pn (40/30°C)	%	108.7	108.7
Useful efficiency P min (40/30°C)	%	109,6	109.6
Chimney losses with burner on (100% Pn) (80/60°C)	%	1.80	1.80
Chimney losses with burner on (P min) (80/60°C)	%	1.50	1.50
Chimney losses with burner off	%	0.01	0.01
Casing losses with burner off	%	0.28	0.28
Casing losses with burner on (100% Pn) (80/60°C)	%	0.20	0.20
Casing losses with burner on (P min) (80/60°C)	%	0.50	0.50
Flue temperature Maximum Heat Input	°C	52	53
Flue temperature Minimum Heat Input	°C	44	46
Flue flow rate at Maximum Heat Input	kg/h	179	179
Flue flow rate at Minimum Heat Input	kg/h	50	49
CO ₂ at the Maximum Heat Input	%	9.4	10.7
CO ₂ at the Minimum Heat Input	%	8.9	10.3
CO at Maximum Heat Input	mg/kWh	230	253
CO at Minimum Heat Input	mg/kWh	11	12
NO _x at the Maximum Heat Input	mg/kWh	50	65
NO _x at the Minimum Heat Input	mg/kWh	25	35
Weighted CO	mg/kWh	19	-
Weighted NO _x	mg/kWh	28	-
NO _x class	-	5	5
Head available at fan (B ₂₃) (Min. - Max.)	Pa	6 - 235	
Head available at fan (C ₁₃) (Min. - Max.)	Pa	215 - 430	

Gas flow rates refer to the NHV at the temperature of 15° C and pressure of 1013 mbar.

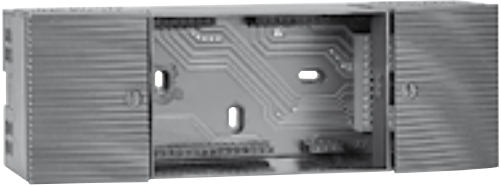

Flue temperature values refer to an air inlet temperature of 15°C and flow temperature of 50°C.



VICTRIX 90 - 115

33	OPTIONAL	
<p>Cascade and zone regulator kit code 3.015244</p> 	<p>Support kit for fixing the regulator to the wall code 3.015265</p> 	
<p>Zone manager kit code 3.015264</p> 	<p>External probe kit code 3.015266</p> 	
<p>Modulating room thermostat kit code 3.015245</p> 	<p>System flow probe kit code 3.015267</p> 	
<p>DHW probe kit for separate storage tank (for storage tank unit managed as zone) code 3.015268</p> 	<p>Anti-freeze electric resistances kit (-15 °C) code 3.015361</p> 	

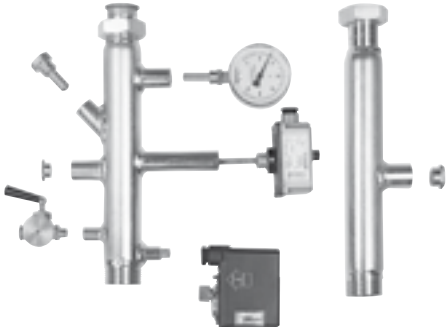
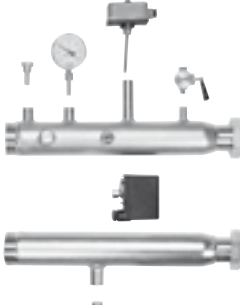
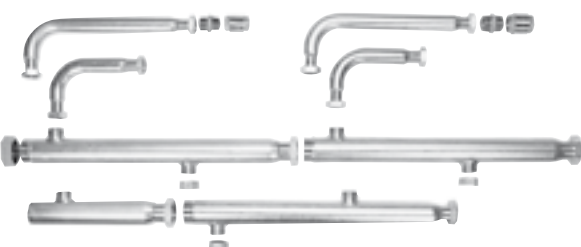
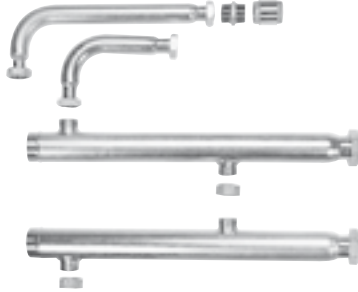

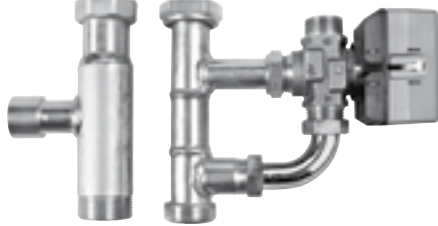
<p>Individual boiler ISPEL safety devices stub pipes kit code 3.015222</p> 	<p>Boilers in cascade ISPEL safety devices stub pipes kit code 3.015227</p> 
<p>Individual boiler ISPEL safety devices kit IPX4D protection box kit code 3.019175</p>	<p>Boiler in set configuration ISPEL safety devices kit IPX4D protection box kit code 3.019185</p>
<p>Hydraulic manifold connection kit with two boilers in cascade configuration code 3.015225</p> 	<p>Additional boiler in cascade hydraulic manifold kit code 3.015226</p> 
<p>Individual boiler hydraulic manifold kit code 3.015224</p> 	<p>Three-way valve kit for coupling Separate storage tank unit (including storage tank probe) (must not be coupled to cascade regulator) code 3.015223</p> 
<p>Individual boiler condensate passivator kit (including granulate) code 3.019857</p>	<p>Boiler in cascade configuration condensate passivator kit (including granulate) code 3.019464</p>

VICTRIX 90 - 115

<p>Granulate reload kit for condensate passivator code 3.019865</p>	<p>Flue exhaust manifold kit Ø 160 with flue adjusting device with 2 VICTRIX 90 boilers or 2 115 boilers in cascade configuration code 3.020476</p>
<p>Flue exhaust manifold kit Ø 160 with flue adjusting devices with additional VICTRIX 90 boiler in cascade configuration code 3.020701</p>	<p>Flue exhaust manifold kit Ø 200 with flue adjusting devices with additional VICTRIX 115 boiler in cascade configuration code 3.020954</p>
<p>Solar collector temperature probe kit (to be coupled with cascade regulator) code 3.019374</p>	



CERTIFICATO DI ESAME CE DI TIPO

EC TYPE EXAMINATION CERTIFICATE

No. **51B02448**

VISTO L'ESITO DELLE VERIFICHE CONDOTTE IN CONFORMITÀ ALL'ALLEGATO II, PUNTO 1,
DEL DPR 15/11/96, N. 661, ATTUAZIONE DELLA DIRETTIVA 90/396/CEE,
SI DICHIARA CHE I SEGUENTI PRODOTTI (MODELLO/TIPO):

*On the basis of our assessment carried out according to Annex II, section 1,
of Legislative Decree of 1996/11/15, No. 661, national transposition of the Directive 90/396/EEC,
we hereby certify that the following products (model/type):*

Caldae murali
Wall mounted boilers

***Mod. VICTRIX 50..., VICTRIX 75..., VICTRIX 90...,
VICTRIX 100..., VICTRIX 115..., VICTRIX 150...***

(ulteriori informazioni sono riportate in allegato)
(for further information see annex)

FABBRICANTE:
Manufacturer:

IMMERGAS SPA
VIA CISA LIGURE 95
42041 BRESCELLO RE

SODDISFANO LE DISPOSIZIONI DEL DECRETO SUDETTO.
Meet the requirements of the aforementioned national legislation.

QUESTO CERTIFICATO DI ESAME CE DI TIPO È RILASCIATO DA IMQ QUALE ORGANISMO NOTIFICATO
PER LA DIRETTIVA 90/396/CEE.

IL NUMERO IDENTIFICATIVO DELL'IMQ QUALE ORGANISMO NOTIFICATO È: **0051**

*This EC Type Examination Certificate is issued by IMQ as Notified Body for the Directive 90/396/EEC.
Notified Body notified to European Commission under number: 0051*

QUESTO CERTIFICATO DI ESAME CE DI TIPO CONSENTE L'APPUNZIONE DELLA MARCATURA
CE SUI PRODOTTI IN QUESTIONE A CONDIZIONE CHE SI SODDISFATTA UNA DELLE PROCEDURE DI VALI-
TAZIONE DELLA CONFORMITÀ DI CUI ALL'ART. 6, COMMA 1, LETTERA b) DEL DPR 15/11/96 N. 661

*This EC Type Examination Certificate allows the affixing of EC marking on the above products if it is notifi-
ed one of the procedures of evaluation conformity of article six(1)(b) of Legislative Decree of
1996/11/15 no.661*

2009-11-24

DATE

IMQ

VIA QUENTRILANO 41 - 20138 MILANO

IL PRESENTE CERTIFICATO ANNULLA E SOSTITUISCE IL PRECEDENTE DEL **2009-08-04**
This Certificate cancels and replaces the previous one of

During the useful life of the products, performance is affected by external factors, e.g. the hardness of the DHW, atmospheric agents, deposits in the system and so on. The data declared refer to new products that are correctly installed and used with respect to the Standards in force.

N.B.: correct periodical maintenance is highly recommended.

Immergas reserves the right to make any modifications to its models, which are believed useful for the development of the product, without forewarning.
Code S.0138 rev. 000 - 02/2010 - *Designs and Estimates Dept. (Consultancy, Dir.)*

www.immergas.com

To request further specific details, Sector professionals can use of the following e-mail:

consulenza@immergas.com

Immergas S.p.A.
42041 Brescello (RE) - Italy
Tel. 0522.689011
Fax 0522.680617



IMMERGAS
SISTEMA DI QUALITA'
CERTIFICATO
UNI EN ISO 9001:2000

Design, manufacture and after-sales assistance of gas boilers, gas water heaters and relative accessories